

REPORT DOCUMENTATION PAGE

*Form Approved
OMB No. 0704-0188*

The public reporting burden for this collection of information is estimated to average 1 hour per response, including the time for reviewing instructions, searching existing data sources, gathering and maintaining the data needed, and completing and reviewing the collection of information. Send comments regarding this burden estimate or any other aspect of this collection of information, including suggestions for reducing the burden, to Department of Defense, Washington Headquarters Services, Directorate for Information Operations and Reports (0704-0188), 1215 Jefferson Davis Highway, Suite 1204, Arlington, VA 22202-4302. Respondents should be aware that notwithstanding any other provision of law, no person shall be subject to any penalty for failing to comply with a collection of information if it does not display a currently valid OMB control number.

PLEASE DO NOT RETURN YOUR FORM TO THE ABOVE ADDRESS.

1. REPORT DATE (DD-MM-YYYY) 06-07-2007		2. REPORT TYPE THESIS		3. DATES COVERED (From - To)	
4. TITLE AND SUBTITLE OPTIMIZATION AND DEVELOPMENT OF A HUMAN SCENT COLLECTION METHOD				5a. CONTRACT NUMBER	
				5b. GRANT NUMBER	
				5c. PROGRAM ELEMENT NUMBER	
6. AUTHOR(S) CAPT FLETCHER KENDRA S				5d. PROJECT NUMBER	
				5e. TASK NUMBER	
				5f. WORK UNIT NUMBER	
7. PERFORMING ORGANIZATION NAME(S) AND ADDRESS(ES) UNIFORMED SERVICES UNIV OF HEALTH SCIENC				8. PERFORMING ORGANIZATION REPORT NUMBER CI07-0052	
9. SPONSORING/MONITORING AGENCY NAME(S) AND ADDRESS(ES) THE DEPARTMENT OF THE AIR FORCE AFIT/ENEL, BLDG 16 2275 D STREET WPAFB OH 45433				10. SPONSOR/MONITOR'S ACRONYM(S)	
				11. SPONSOR/MONITOR'S REPORT NUMBER(S)	
12. DISTRIBUTION/AVAILABILITY STATEMENT Unlimited distribution In Accordance With AFI 35-205/AFIT Sup 1					
<p>DISTRIBUTION STATEMENT A Approved for Public Release Distribution Unlimited</p>					
13. SUPPLEMENTARY NOTES					
14. ABSTRACT					
15. SUBJECT TERMS					
16. SECURITY CLASSIFICATION OF:			17. LIMITATION OF ABSTRACT	18. NUMBER OF PAGES 90	19a. NAME OF RESPONSIBLE PERSON
a. REPORT	b. ABSTRACT	c. THIS PAGE			19b. TELEPHONE NUMBER (Include area code)

Abstract

Title: OPTIMIZATION AND DEVELOPMENT OF A HUMAN SCENT COLLECTION METHOD

Kendra S. Fletcher, Master of Science in Public Health, 2007

Directed By: Peter LaPuma, Lt Col, USAF, BSC
Assistant Professor
Department of Preventive Medicine and Biometrics

Canines have been used by law enforcement to detect human scent, narcotics, and explosives. Matching human scent using analytical instruments would add credibility to a canine's response. Traditionally, air passed through cotton pads has been used to collect scent at crime scenes. While this collection technique preserves forensic evidence and is adequate for canines, chemical analysis of scent samples may require better collection techniques. Optimization of the collection of 10 human scent compounds on cotton pads was performed by adjusting the collection flow rate and extraction time. Maximum recovery (1.8%) was achieved at a low flow rate (50 ft/min) and a short extraction time (54 secs), 7.6 cm from the analyte source. Alternative collection media were tested and revealed that use of solid-phase microextraction (SPME) collection techniques increase the recovery (4.4%) of human scent compounds. Advanced collection techniques, such as SPME, will be needed for chemical analysis of human scent.



UNIFORMED SERVICES UNIVERSITY OF THE HEALTH SCIENCES
 F. EDWARD HÉBERT SCHOOL OF MEDICINE
 4301 JONES BRIDGE ROAD
 BETHESDA, MARYLAND 20814-4799



June 4, 2007

BIOMEDICAL
 GRADUATE PROGRAMS

Ph.D. Degrees

Interdisciplinary
 -Emerging Infectious Diseases
 -Molecular & Cell Biology
 -Neuroscience

Departmental
 -Clinical Psychology
 -Environmental Health Sciences
 -Medical Psychology
 -Medical Zoology
 -Pathology

Doctor of Public Health (Dr.P.H.)

Physician Scientist (MD/Ph.D.)

Master of Science Degrees

-Molecular & Cell Biology
 -Public Health

Masters Degrees

-Military Medical History
 -Public Health
 -Tropical Medicine & Hygiene

Graduate Education Office

Dr. Eleanor S. Metcalf, Associate Dean
 Janet Anastasi, Program Coordinator
 Tanice Acevedo, Education Technician

Web Site

www.usuhs.mil/geo/gradprog_index.html

E-mail Address

graduateprogram@usuhs.mil

Phone Numbers

Commercial: 301-295-9474
 Toll Free: 800-772-1747
 DSN: 295-9474
 FAX: 301-295-6772

APPROVAL SHEET

Title of Thesis: "Optimization and Development of a Human Scent Collection Method"

Name of Candidate: Capt Kendra Fletcher
 Department of Preventive Medicine & Biometrics
 Master of Science in Public Health
 31 May 2007

Thesis and Abstract Approved:

//Signed//

 Lt Col Peter LaPuma, USAF
 Department of Preventive Medicine & Biometrics
 Thesis Advisor

11 Jun 07
 Date

Greg Cook
 LCDR Greg Cook, USN
 Department of Preventive Medicine & Biometrics
 Committee Member

15 JUN 07
 Date

Brian Eckenrode
 Brian Eckenrode, Ph.D.
 Federal Bureau of Investigation, Quantico, VA
 Committee Member

6/13/07
 Date

The author hereby certifies that the use of any copyrighted material in the thesis manuscript entitled:

**“OPTIMIZATION AND DEVELOPMENT OF A HUMAN SCENT
COLLECTION METHOD”**

is appropriately acknowledged and, beyond brief excerpts, is with the permission of the copyright owner.



Kendra S. Fletcher, Capt, USAF, BSC
Department of Preventive Medicine and Biometrics
Uniformed Services University of the Health Sciences

Abstract

Title: OPTIMIZATION AND DEVELOPMENT OF A HUMAN SCENT COLLECTION METHOD

Kendra S. Fletcher, Master of Science in Public Health, 2007

Directed By: Peter LaPuma, Lt Col, USAF, BSC
Assistant Professor
Department of Preventive Medicine and Biometrics

Canines have been used by law enforcement to detect human scent, narcotics, and explosives. Matching human scent using analytical instruments would add credibility to a canine's response. Traditionally, air passed through cotton pads has been used to collect scent at crime scenes. While this collection technique preserves forensic evidence and is adequate for canines, chemical analysis of scent samples may require better collection techniques. Optimization of the collection of 10 human scent compounds on cotton pads was performed by adjusting the collection flow rate and extraction time. Maximum recovery (1.8%) was achieved at a low flow rate (50 ft/min) and a short extraction time (54 secs), 7.6 cm from the analyte source. Alternative collection media were tested and revealed that use of solid-phase microextraction (SPME) collection techniques increase the recovery (4.4%) of human scent compounds. Advanced collection techniques, such as SPME, will be needed for chemical analysis of human scent.

**OPTIMIZATION AND DEVELOPMENT OF A
HUMAN SCENT COLLECTION METHOD**

By

Capt Kendra Fletcher

Thesis submitted to the Faculty of the Department of Preventative Medicine
and Biometrics of the Uniformed Services University
of the Health Sciences in partial fulfillment of the
requirements for the degree of
Master of Science in Public Health 2007

Dedication

I dedicate this thesis to myself because without me it could not have gotten done!

Acknowledgements

Thank you to each of the following individuals for their support and patience:

- Lt Col Peter LaPuma, Uniformed Services University of the Health Sciences
- Brian Eckenrode, FBI Counterterrorism Forensic Science Research Unit
- LCDR Greg Cook, Uniformed Services University of the Health Sciences
- Capt Robbie Wheeler, Uniformed Services University of the Health Sciences
- Dennis Maslanka, FBI Counterterrorism Forensic Science Research Unit
- Wynn Warren, FBI Evidence Response Team Unit
- Rex Stockham, FBI Evidence Response Team Unit

Table of Contents

Approval Sheet.....	i
Copyright Sheet	ii
Abstract.....	iii
Title Page	iv
Dedication.....	v
Acknowledgements.....	vi
Table of Contents.....	vii
List of Figures	x
List of Tables	xii
List of Symbols and Abbreviations.....	xiii
Chapter 1. Background	1
Research Objectives.....	4
Chapter 2. Literature Review	5
2.1. Human Scent Compounds	5
2.1.1. Elucidation of Human Scent Compounds.....	5
2.1.1.1. Human Malodor	6
2.1.1.2. The Human Scent Profile.....	7
2.1.1.3. Human Skin Volatiles.....	10
2.1.1.3. Human Cadavers	12
2.2. Use of Canines in Crime Investigations	15

2.2.1. Canine Scent Line-Up.....	15
2.2.2. Canine Scent Trailing	17
2.3. Scent Transfer Unit (STU-100)	18
2.3.1. Performance Evaluation.....	19
2.3.1.1. Flow Rate Determination.....	20
2.3.1.2. Sample Differentiation.....	20
2.3.1.3. Alternative Sample Collection Media.....	22
2.3.1.4. Cotton Pad Absorption/Desorption Efficiency Evaluations	23
Chapter 3. Methodology	26
3.1. Method Development	26
3.2. Analytical Technique.....	28
3.2.1. Sample Preparation	30
3.2.2. Analyte Delivery to the STU-100 and HSA SPME.....	31
3.2.3. Collection Media Loading	33
3.2.4. Collection Media Desorption.....	36
3.2.5. Sample Concentration and Analysis	37
3.2.6. Static SPME Experiment	42
Chapter 4. Results	43
4.1. Calibration Curves	43
4.2. Blanks	44
4.3. Simplex Optimization	45
4.4. Comparison of Distance From Analyte Source.....	49

4.5. Surgical Dressing Size Comparison	51
4.6. Alternative Collection Media Comparison.....	53
Chapter 5. Conclusions	57
5.1. Experimental Results	57
5.2. Study Limitations.....	59
5.3. Future Research	59
Appendix A: Calibration Curve Calculations	60
Appendix B: Capture Distance Calculations	64
Appendix C: Calculations of Percent Recovery for Released Targeted Compounds.....	65
Appendix D: Simplex Method Detail	67
Bibliography	72
Curriculum Vitae	77

List of Figures

Figure 2-1. The Scent Transfer Unit (STU-100)	19
Figure 3-1. Schematic of Overall Experimental Process	29
Figure 3-2. Schematic of Modified STU-100 Face Plate	34
Figure 3-3. Three Types of Cotton Pads Tested	35
Figure 3-4. HSA-SPME Device Cross-Sectional View [38]	36
Figure 3-5. Example of a Completed Variable-Size Simplex Optimization [40]	42
Figure 4-1. Modified STU-100 Flow Rate with a Surgical Dressing in Place	45
Figure 4-2. First Simplex Based on Researcher Chosen Data Points	46
Figure 4-3. Plot of STU-100 Simplex Optimization	47
Figure 4-4. Combined Percent Recovery From Surgical Dressing	48
Figure 4-5. Combined Percent Recovery from Surgical Dressing	49
Figure 4-6. Combined Percent Recovery of Varying Distances of Delivery Pump Outlet to STU-100 Face	50
Figure 4-7. Diagram of Analyte Dispersal at Different Distances from Surgical Dressing	51
Figure 4-8. Combined Percent Recovery of Different Cotton Pad Sizes	52
Figure 4-9. Diagram of Analyte Contact Area on Different Sized Surgical Dressings	53
Figure 4-10. Comparison of Combined Percent Recoveries for Different Collection Media	54
Figure A-1. Example of a Calibration Curve Generated Using Adjusted Peak Area	62
Figure A-2. Example of a Calibration Curve Generated Using Unadjusted Peak Area	63
Figure D-1. A Two-Factor Simplex [40]	68

Figure D-2. Vertex R is the Reflection of the Discarded Vertex W [40].	69
Figure D-3. An Example of a Completed Basic Simplex Optimization [40].	70
Figure D-4. All Possible Vertices in the Variable-Size Simplex Algorithm [40]	71

List of Tables

Table 2-1. Top 20 Compounds Identified in Human Skin Emanations.....	12
Table 2-2. Most Significant Chemicals Detected at the Surface of One-Year-Old Burials [17].....	14
Table 3-1. List of Human Scent Compounds Used	30
Table 3-2. Physical Properties of Selected Human Scent Compounds and Concentration in Tedlar™ Bags Used for Experimentation.....	31
Table 3-3. Entech 7100 Preconcentrator Operating Conditions	38
Table 3-4. GC/MS Operating Conditions	39
Table 4-1. Adjusted Peak Areas for Calibration Curves.....	43
Table 4-2. Concentration of Analytes in Blank Samples.....	44
Table 4-3. Percent Recovery of Human Scent Compounds for Five Collection Media	55
Table 4-4. Number of Human Scent Compounds Collected by Each Collection Media	56
Table A-1. Calibration Curve Mixture Volumes	61
Table A-2. Calibration Curve Equations Based on Adjusted Peak Area.....	61
Table A-3. Calibration Curve Equations Based on Unadjusted Peak Areas	62

List of Symbols and Abbreviations

amu	atomic mass unit
cfm	cubic feet per minute
cm	centimeter
FBI	Federal Bureau of Investigation
ft/min	feet per minute
ft	feet
FTIR	Fourier transform infrared
g	gram
GC	gas chromatography
GC/MS	gas chromatography-mass spectroscopy
HSA-SPME	high surface area solid phase microextraction
in.	inch
L	liter
LTM	low thermal mass
L/min	liters per minute
min	minute
mg	milligram
mL	milliliter
mm	millimeter
MS	mass spectrometer
mw	molecular weight
ng	nanogram
ppb _v	parts per billion volume
ppb _w	parts per billion weight
ppm _v	parts per million volume
psi	pound-force per square inch
RSD	relative standard deviation
Rt	retention time
sec	second
SPME	solid phase microextraction
STU-100	scent transfer unit
ρ	density
μg	microgram
μL	microliter

Chapter 1. Background

Canines have been used for hundreds of years to hunt and track people. More recently canines have been used to detect narcotics, arson accelerants, explosives, and cancer. Canines are used in law enforcement to trail, track, and match human scent samples. Unique training is required for these three tasks, which are very different. Trailing canines are presented with an object scented by an individual and they then determine if that same scent is present in a specific area. Tracking canines rely on both human scent and environmental disturbances (i.e. footprints, broken tree limbs or twigs) to follow an individual's trail. Tracking canines are not given an initial human scent to follow. Scent-matching canines are presented with an object scented by an individual and they are trained to match that to another scented object. In the Netherlands, Germany, Belgium and Poland, canine scent line-ups are used in law enforcement to match human scent samples to suspected criminals. In a scent line-up the canine is exposed to an object from a crime scene and is then exposed to metal bars that have been handled by different individuals including the suspect.

Trace evidence at a crime scene can include any foreign object (i.e. hair, fibers, cells, fingerprints, dirt, pollen, footprints, and human scent). Forensic science is concerned with the collection and analysis of evidence, including trace evidence. Trace evidence alone may not be enough to lead to a conviction, but trace evidence does provide corroborative information. Locard's Principle of Exchange has been the driving force behind the development of forensic science. Locard's principle states that everywhere a person physically goes they leave behind something and likely take

something with them. Human scent is left behind where an individual goes and can be a key piece of trace evidence in solving crimes, locating suspects, or locating prisoners of war.

Human scent is a form of trace evidence that is left behind at crime scenes and can be collected by several different methods. An object from a crime scene can be directly presented to a canine or the surface of an object of interest can be wiped with collection media, which is then presented to the canine. Another collection technique, involving adsorption, requires that the collection media be placed near or directly on the object of interest for a period of time. A modification of this technique requires that the object of interest be placed in an enclosure (i.e. a plastic bag or glass jar) with the collection media for a period of time. The main problem with these collection techniques is that all have the potential to destroy, disturb, or contaminate other forensic evidence. For this reason, the Scent Transfer Unit (STU-100) was developed in 1996 as an alternative human scent collection technique. The STU-100 collects human scent from crime scenes using a vacuum pump that pulls air over the collection media (a cotton pad). Human scent evidence can be collected using this technique without disturbing a crime scene and be subsequently presented to a canine. The STU-100 has been adopted by many law enforcement agencies in the United States [1].

Evidence admitted into a United States court of law must comply with the rulings of two landmark cases. These rulings were established to ensure that when a new type of evidence or new method of evidence analysis is introduced, it has been adequately tested and accepted by experts in that particular field. The "Frye Test," established in the 1923 case, *Frye vs. United States*, states that the basis of expert scientific evidence must be

"sufficiently established to have gained general acceptance in the particular field in which it belongs." The Frye Test prevents an expert witness from presenting testimony on a subject which has not been researched, established, and accepted. Further evidentiary requirements were established in the 1993 Supreme Court case of *Daubert vs. Merrell Dow Pharmaceuticals*. This ruling requires judges to ensure that evidence is based upon a generally accepted, peer-reviewed, testable theory that has a known error rate. Therefore, evidence collection and evaluation techniques must be scientifically validated to ensure admissibility in court.

The use of a canine's response to human scent in court is highly controversial. For a canine's response to be admissible it must meet the requirements of *Frye* at a minimum and eventually *Daubert*. Currently in the United States, the training, certification, and use of canines in law enforcement are not standardized. Since different training techniques could lead to different responses from canines in the same situation, scientific validation of the canine response is needed. Ideally, a human scent sample acquired at a crime scene would be chemically analyzed and compared to another scent sample taken from a suspect or a location where a suspect has been. However, human scent matching is a complicated task due to the complex composition of human scent. In addition, the chemical compounds canines use to match human scent samples are currently unknown. Canines' ability to match human scent samples implies that human scent is unique and persistent. Recent studies indicate that the identifiable compounds and relative abundance of those compounds found in human sweat vary within the same day and from day to day in the same individual, but produce compound ratio patterns that are distinguishable among different individuals [2]. Furthermore, canines respond to

human scent compounds at concentrations lower than what is currently detectable by a gas chromatograph/mass spectrometer (GC/MS), the current “gold standard” technology for compound identification and quantitation. Therefore, canines may be basing their human scent matching on compounds that are at levels that current instrumentation may not be able to detect.

GC/MS has been widely used in analytical chemistry to detect and quantify a wide range of chemicals (i.e. chemical warfare agents, pesticides, food products, and industrial chemicals). Due to the GC/MS’s versatility and specificity it is has been previously used in research for identifying and quantifying human scent compounds [2-11].

The STU-100’s ability to collect the compounds that make up a unique human scent sample must be maximized to eventually be able to replicate the canine response in the laboratory and permit optimal chemical analysis of scent samples. The efficiency of the collection of human scent compounds by the STU-100’s collection methodology has not been fully evaluated or optimized.

Research Objectives

1. Optimize the collection media’s sampling and room temperature desorption of 10 human scent compounds by adjusting the STU-100’s vacuum pump flow rate and extraction time simultaneously.
2. Compare the collection and desorption efficiency of 10 human scent compounds using four alternative collection media (two different types of cotton pads (Dutch and Hungarian), a carbon-coated foam, and a prototype high surface area solid-phase microextraction (HSA-SPME) device).

Chapter 2. Literature Review

This research focused on improving the collection and desorption of 10 human scent compounds from collection media using an STU-100. By optimizing the collection and desorption of human scent compounds, a GC/MS may be better able to detect and analyze human scent compounds and thus be able to corroborate a canine's response. The following paragraphs briefly discuss the research that has been conducted to identify human scent compounds, to understand the canine's ability to trail, track, and match human scent samples, the evaluation and performance of the STU-100, and GC/MS analysis techniques of human scent compounds.

2.1. Human Scent Compounds

The composition of human scent is complex due to the number and variation in the compounds identified in human emanations. The composition of human scent is not well understood but is critical in corroborating the canine response with instrumentation.

2.1.1. Elucidation of Human Scent Compounds

Not all human scent compound elucidation research has been in pursuit of canine response corroboration. Substantial research has focused on determining the constituents of human malodor, which does not represent a complete human scent profile. Humans may or may not smell the same compounds that canines smell. Research has also been done on which human emanations attract mosquitoes and within the cosmetics industry.

This study will focus on compounds that are found in a complete human scent profile and not just those compounds that have been identified as human malodor constituents.

2.1.1.1. Human Malodor

Many studies have been conducted to determine what compounds cause human malodor. Since malodor is a relative term, all of these studies include organoleptic evaluation, or the judging of malodor by a panel of individuals.

In 1990, researchers evaluated the compounds responsible for foot malodor. GC/MS was used to analyze extracts from socks of individuals judged to have strong or no foot malodor. Analysis revealed that short-chained carboxylic acids were primarily responsible for foot malodor because they were detected in greater amounts in the individuals judged to have strong foot malodor. In particular, isovaleric acid was detected in individuals with foot malodor but not detected in individuals without foot malodor. [4]

In another study, the underarm sweat of six males was combined and analyzed using GC/MS and GC Fourier Transform Infrared Spectra (GC/FTIR). This study found that a number of short-chained carboxylic acids are important components of axillary odor. Specifically, C₆-C₁₁ straight-chained, branched, and unsaturated carboxylic acids were determined to be important contributors. (E)-3-methyl-2-hexenoic acid was determined to be the main component of axillary odor. While odor generating compounds were the primary focus of this study, many odorless compounds were identified in the emanations as well. [5] A subsequent study examined the composition and character of female axillary emanations. This study found that the same odorous

compounds that were previously identified in male axillary emanations were present in female emanations. Minor qualitative differences were found between the two sexes. [7]

A follow-on study was conducted to identify the odorless precursors present in male axillary sweat. Apocrine emanations are odorless until acted on by microorganisms present on the skin. Apocrine emanations of several males were combined and then separated into organic and aqueous phases. GC/MS was used to determine which fraction contained the previously identified odor contributor, (E)- and (Z)-3-methyl-2-hexenoic acid. The results of this study suggest that the odor precursors are present in the aqueous soluble fraction of apocrine emanations. [6]

Additional malodor research was conducted to determine how laundering affects clothing odor. After washing, axillary sweat contaminated clothing was still found to contain esters, ketones, and aldehydes, which were identified as the primary odorants of the laundered clothing. Carboxylic acids, which are known to be primary axillary sweat odorants, were effectively removed with laundering. [8]

2.1.1.2. The Human Scent Profile

Human malodor compounds are only one part of the human scent profile. A human scent profile is considered to contain odor causing and odorless compounds. The following studies focus on the human scent profile and not only malodor as the previous studies did.

The identification of human skin emanations is critical information when determining mosquito attractants. Research has been done in this field using handled glass beads to collect non-aqueous human skin emanations. Four male individuals were sampled in one study. The material collected on the glass beads was analyzed by

GC/MS. The compounds identified were similar among the individuals, however the relative amounts varied. Two-hundred and seventy-seven compounds were identified as potential mosquito attractants. Although a large number of compounds were identified, the authors suggest that all of the important compounds have not yet been detected and identified. [12, 13]

In another study that focused on mosquito attraction, glass beads were handled by two individuals, one previously identified as being “highly attractive” to mosquitoes and one that was “not as attractive” to mosquitoes. GC/MS analysis of the beads revealed that the two samples contained similar compounds; however, the relative amounts of each of the compounds were significantly different between the individuals. Forty-five compounds were in much greater abundance in the “highly attractive” individual. The variability of human emanations from day to day in the same individual was also explored. There was less variability in the samples in the same individual from day to day when compared to samples from other individuals, but some changes in compound abundance were observed. The compounds that increased when the individual was more attractive to mosquitoes did not necessarily attract mosquitoes when tested in a pure state. Again, the authors note that it is possible that not all of the mosquito attractants that humans emit were able to be collected and detected using the method employed in this research. [14]

One human scent study used a GC and flame ionization detector (FID) to analyze the compounds present in human sweat. This research produced odor profiles of approximately 200 compounds; however the compounds were not identified. Differences in the odor profiles of individuals of varying ethnic backgrounds were observed. The

authors noted that if a “body odour equivalent of the fingerprint method of identification” could be realized that it would be useful in law enforcement. [15]

Research has been done to determine if odor profiles among individuals are unique. Chromatogram pattern matching was used to determine if individual odor profiles could be established. Headspace samples of axillary sweat from two pairs of twins were used to generate chromatograms using a GC/FID. The chromatograms showed that “human identity is signaled by qualitative and quantitative differences in the sweat volatiles.” The odor profile of each twin was significantly more similar to his/her twin than to an unrelated individual. However, there were slight differences between twins as well, indicating that unique odor profiles exist among individuals with the same DNA. The results also indicated that the twins’ odor profiles were most similar in terms of the concentration of certain volatiles. [16]

In another study exploring human scent uniqueness, two males’ axillary emanations were analyzed. The individuals wiped their armpit with a gauze pad after one hour of exercise. The gauze pads were then immediately sealed in glass vials. SPME and GC/MS were used for volatile collection and analysis, respectively. The mass spectra were evaluated and relative ratios were computed with respect to (E)-2-nonenal, a compound identified in each sample. The study found that human scent varied between individuals both quantitatively and qualitatively. The ratios of 13 compounds in the same individual were similar when sampled at different times during the same day or weeks apart. This study concluded that the compound ratio pattern produced by an individual was reproducible over time and allowed for chromatographic distinction between individuals. In addition, volatile scent compounds were retained on gauze pads almost

three months after collection. This study provided insight into the uniqueness and persistence of human scent compounds. [2]

Axillary emanations from four males and four females were collected and analyzed using SPME-GC/MS. Individuals wiped their armpit with a gauze pad after 30 minutes of exercise. The majority of the compounds identified were esters and aldehydes. Quantitative differences between individuals were evaluated by using compound ratios with respect to decanal. (E)-3-methyl-2-hexenoic acid was not detected in this study, but was determined to be a major contributor to axillary odor by Zeng et al.[5, 7]. In addition, 2-nonenal, which was previously identified as an age-specific odor compound in those over 40 [9], was identified in individuals younger than 25. This study concluded that a human scent profile is distinctive due to both qualitative and quantitative differences between individuals. [3]

The effect of aging on the human odor profile was investigated in another study. Twenty-two individuals (ages of 26 to 75) wore clean cotton shirts for three nights. A piece of each shirt was then cut from the back area and analyzed using GC/MS. 2-nonenal was found only in individuals 40 years or older. Unsaturated fatty acids and lipid peroxides were shown to increase with aging. [9]

2.1.1.3. Human Skin Volatiles

The volatiles released by human skin are important to the cosmetics industry because they affect how cosmetic products perform once applied to the skin. In 2001, a study was conducted using SPME to collect headspace samples from vials attached directly to the forearms of 50 females. GC/MS was used to analyze the samples. Volatile compounds identified in most individuals included short-chained aldehydes and

longer-chained hydrocarbons. Less commonly found were a branched ketone, residuals of cosmetics and fragrances, glycols, and hydrocarbons of shorter chain length. The relative amounts of all compounds differed among the individuals. [10]

While the studies previously discussed had different aims (human malodor, human scent profile, human skin volatiles), all suggest that human skin emanations are highly complex and differ between individuals. Table 2-1 lists the 20 most frequently identified compounds in human emanations. The compounds in Table 2-1 are grouped according to where the sample was taken from the individual. The lack of commonality in the compounds identified in each study indicates that human odor signatures are complex and vary significantly between individuals.

Table 2-1. Top 20 Compounds Identified in Human Skin Emanations

Author:	Axillary						Hands	Feet	Back	Forearm	
	Zeng, 1991	Zeng, 1992	Zeng, 1996	Munk, 2000	Curran, 2005	Curran, 2005	Bernier, 2000	Bernier, 2002	Kanda, 1990	Haze, 2001	Ostrovaska, 2001
Number of subjects:	6	28	6	14	2	8	4	2	10	22	50
decanoic acid (capric acid)	X	X	X				X	X	X		
hexanoic acid (caproic acid)	X	X	X	X					X		
2-nonenal				X	X	X				X	
6-methyl-5-hepten-2-one					X	X		X			X
dodecanoic acid					X	X	X	X			
heptanal					X	X		X		X	
heptanoic acid (enanthic acid)	X		X	X					X		
hexanal				X	X	X				X	
nonanal					X			X		X	X
nonanoic acid (pelargonic acid)		X	X			X			X		
octanal				X	X					X	X
octanoic acid (caprylic acid)	X	X	X						X		
phenol	X		X		X	X					
3-methyl-2-hexenoic acid	X	X	X								
7-octenoic acid	X	X	X								
decanal					X					X	X
hexadecanol	X		X							X	
nonane					X	X		X			
toluene					X	X		X			
undecanoic acid	X	X	X								

2.1.1.3. Human Cadavers

Volatiles collected from cadavers are known to differ from those that emanate from living individuals. After death there are many degradation processes that occur which contribute to the volatile compounds released by a cadaver. A study was conducted to determine the compounds that canines use to identify human remains. SPME was used to collect volatiles from cadavers; the samples were analyzed by GC/MS. The compounds identified in the cadavers include: cadaverine, putrescine, indole, skatole, dimethyl sulfides, and organic fatty acids. Cadaver canines gave positive

responses to cadaverine, putrescine, indole and skatole in field tests. Further tests are ongoing to determine if there are additional compounds that cadaver canines alert to and to verify previous responses with additional canines. This information would make it possible to develop more effective training aids for canines. [11]

A subsequent study focused on identifying the volatile and semivolatile compounds emitted from buried cadavers. A Decompositional Odor Analysis Database was developed to aid in understanding the human decay process based on the chemicals released over time. Air samples were collected above and below four buried cadavers. Four-hundred and twenty-four chemicals were emitted from the buried cadavers. Table 2-2 lists the chemicals that were considered to be most significant, which were detected in burial sites that were 1-year old (three cadavers) and 12-years old (one cadaver). There are several chemicals that have been identified in both living humans and cadavers.

Table 2-2. Most Significant Chemicals Detected at the Surface of One-Year-Old Burials [17]

*Indicates that this compound was also considered to be significant in 12-year-old burials.
Shading indicates compound class.

	Compound	Class
Identified in Burials and Living Humans	hexadecanoic acid, methyl ester	acid
	1-hexanol, 2-ethyl*	alcohol
	decanal*	aldehyde
	nonanal*	aldehyde
	heptane*	alkane
	undecane*	alkane
	benzaldehyde	aromatic
	benzene	aromatic
	styrene	aromatic
	toluene*	aromatic
	naphthalene	polyaromatic hydrocarbon
Identified in Burials Only	2-methyl pentane	alkane
	methenamine	amine
	benzene methanol, a,a dimethyl*	aromatic
	1,2 dimethyl benzene	aromatic
	1,4 diemethyl benzene*	aromatic
	1-methyl-2-ethyl benzene	aromatic
	ethyl benzene	aromatic
	benzonitrile	aromatic
	carbon tetrachloride*	haloalkane
	chloroform	haloalkane
	dichlorodifluoromethane*	haloalkane
	dichlorotetrafluoroethane*	haloalkane
	trichloromonofluoromethane*	haloalkane
	trichloroethane	haloalkane
	tetrachloroethene	haloalkene
	trichloroethene*	haloalkene
	2-propanone*	ketone
	1-methyl naphthalene	polyaromatic hydrocarbon
	2,4-dimethylthiane, S,S-dioxide	sulfonated
	benzothiazole	sulfonated
	carbon disulfide	sulfonated
	dimethyl disulfide	sulfonated
dimethyl trisulfide	sulfonated	
sulfur dioxide	sulfonated	

2.2. Use of Canines in Crime Investigations

The use of canines in law enforcement is highly controversial because inconsistencies in canine response to human scent have been observed. The center of the controversy is whether canine scent matching evidence, such as the canine scent line-up and canine trailing techniques, stand up to the rigorous standards set by *Daubert vs. Merrell Dow Pharmaceuticals*. For example, different configurations of canine scent line-ups have resulted in different error rates and veteran trailing canines have performed differently than novice trailing canines.

2.2.1. Canine Scent Line-Up

A canine scent line-up is used to match human scent collected from a crime scene to the scent of a suspect. One study investigated how canine scent line-ups meet the evidential requirements of *Daubert* and *Frye*. *Daubert* and *Frye* require that scientific claims be verifiable, tested and peer reviewed, have a known error rate, have a standardized methodology, and be generally accepted by those knowledgeable in that scientific field of study. The study concluded that canine scent line-ups satisfactorily meet only one of the five criteria (verifiable) of *Daubert* and *Frye*. In addition, the study concluded human identification by canines in general did not have a strong enough scientific foundation to be used as evidence in a court of law. [18]

Another study examined four different variations of the canine scent line-up. This research concluded that the design of a canine scent line-up greatly affects the performance of the canines. Eight canines were tested with four different tasks. The correct identification rates varied from 65% to 26%. While the results indicate that

canines are capable of discriminating between different human scents and perform better than chance predicts, forensic science prerequisites require a higher level of validity than was demonstrated in this study. [19]

A reliability test for canine scent line-ups was evaluated in response to the results of previous studies. Ten experiments (five “suspect = perpetrator” and five “suspect ≠ perpetrator”) were conducted with six canines. Five types of corpora delicti (pistol buttplates, screwdrivers, spanners, sweatshirt cuffs and scent samples collected from car seats using a piece of cotton cloth) were used in the experiments. All of the experiments conducted in this study used a performance check prior to testing the canines which was not done in previous studies. The scent line-up consisted of two rows of seven scented tubes. The tubes included the suspect’s odor, a check person’s odor and the odors of five decoys. The tubes were arranged randomly except that in one row the suspect’s tube was placed before the check person’s tube and in the second row the order was reversed. This was done to ensure that the canine did not have a specific interest in the suspect’s odor. In order to pass the performance check the canine had to match a sample from the check person to the check persons’ tube in both rows. Half of the experiments led to a disqualification due to failure to pass the performance check. In the “suspect = perpetrator” experiments the canine correctly matched the scented object from the suspect to the scented tube in the line up 37% of the time. In the “suspect ≠ perpetrator” experiments the canines correctly did not make a match 47% of the time. The canine scent line-up error rates were comparable to other currently used forensic techniques (bloodstain and hair analyses); however, the canine error rates were worse than fingerprinting and footwear analysis. When the results of a past study of the canine scent

line-up were compared to the results of this study, the use of a performance check prior to testing produced better results than those achieved when a performance check was not used. The performance check has the ability to “weed out” canines that are unable to work normally due to illness, unwillingness to work or lack of motivation. [20]

2.2.2. Canine Scent Trailing

Several experiments have explored canine scent trailing techniques. In one study, eight bloodhounds’ ability to discriminate scent between two individuals was evaluated. An STU-100 was used to collect scent from human targets then the cotton pad was presented to the canines prior to trailing. The canines were tested on old trails (48 hrs old) that many persons had walked on and were exposed to heavy rain and wind. The study concluded that veteran bloodhounds (>18 months of training) performed better than novice bloodhounds (< 18 months of training) with overall find rates of 96 and 53 percent, respectively. One theory that could explain the poor performance of the novice bloodhounds is that the younger canines might not have fully matured neurological systems. The human scent was collected uniformly from all over the body with the STU-100, which suggests that the location of scent collection may not be an important factor as previous research had suggested [21]. [22]

Another study examined the survivability of human scent using pipe bombs and arson devices (gas cans). These objects were handled by individuals and the objects were then burned for two minutes before being extinguished with water. An STU-100 was used to collect human scent samples from the burnt objects. The cotton pads were immediately sealed in polyethylene resealable bags after sample collection and stored at room temperature. Two weeks later, the individuals who handled the objects, prior to

their burning, walked trails in an urban park. The human scent samples collected by the STU-100 were then presented to a total of 20 veteran and novice bloodhound-handler teams who were asked to trail to the correct individual. The bloodhounds trailed to the correct individual 70% of the time with no false positive identifications. The veteran bloodhounds had a higher percentage (81%) of correct identifications than the novice bloodhounds (64%). This study showed that critical human scent compounds can withstand the extreme mechanical and thermal stress of an explosion and that canines could still reliably match that scent to an individual. [23]

The ability of a canine to trail an individual six months after leaving an area was demonstrated during a Federal Bureau of Investigation (FBI) bloodhound research workshop in 2003. A canine was presented a letter sent by an individual from New Mexico, the individual's new place of residence. For the previous seven years the individual had lived in the same residence in Virginia. The canine began at an intersection a few blocks from the individual's previous Virginia residence, which was vacated six months earlier. The canine correctly identified the individual's previous residence from the scent on the letter. [24]

This research shows that scent discriminating canines can provide valuable information about a crime when properly employed. However, caution must be used since canines scent detection abilities and techniques are not yet well understood.

2.3. Scent Transfer Unit (STU-100)

Scent evidence should be one of the first pieces of evidence collected from a crime scene because the presence of other individuals in the area may contaminate the scent evidence [25]. A canine's ability to correctly identify human scent is greatly

diminished if a crime scene is contaminated. Human scent evidence can be collected from almost any surface or object at a crime scene. The STU-100 (see Figure 2-1) was introduced by Tolhurst and Harris in 1996 as an alternative human scent evidence collection device that does not disturb other crime scene evidence and provides a more consistent means to collect scent evidence.

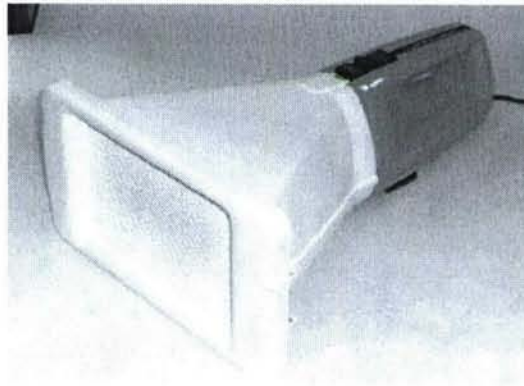

Figure 2-1. The Scent Transfer Unit (STU-100)

The STU-100 is transported in a case that contains a charging system, a 12-volt battery and the control for the vacuum pump. The vacuum pump has a variable speed motor and is used to collect human scent on a sterile cotton pad (12.7 cm x 22.9 cm). The vacuum pump speed settings range from 1.0 to 9.4. Scent can be collected from an article of interest or from the ambient air in a room where a crime occurred. After human scent evidence is collected on a pad, the pad is presented to a canine or stored in an airtight container for later use.

2.3.1. Performance Evaluation

Several studies have been conducted to evaluate and optimize the STU-100's operation. The studies were initiated in response to the need for scent evidence collected by the STU-100 to comply with the standards set forth in *Daubert vs. Merrill Dow*

Pharmaceuticals. In addition, use of the STU-100 in criminal investigations has come under scrutiny by the scientific community. One expert defense witness in scent evidence cases called the use of the STU-100 “quackery” [26]. Five recent criminal convictions in California that used scent evidence collected by the STU-100 were overturned and have spurred more controversy [26]. These recent events emphasize the need for scientific evaluation of the STU-100.

2.3.1.1. Flow Rate Determination

Initial evaluation of the STU-100 began by measuring the face velocity with and without a pad in place. Determination of the STU-100’s face velocity provided insight as to how fast compounds were traveling across the cotton pad at each of the vacuum pump settings. The face velocity was measured at nine locations across the face of the STU-100 (15.2 cm x 9.7 cm). Without a pad with the vacuum pump at its highest setting, the highest face velocities were at the edges (250 ft/min.) and the lowest velocities were at the center of the face (225 ft/min). When a cotton pad was used, the face velocities in the same areas dropped to approximately 75 ft/min. [27]

2.3.1.2. Sample Differentiation

For scent evidence to be useful with analytical instruments, the collected scent must be unique. The following studies were performed to determine if scent samples collected with the STU-100 from different individuals or sources could be distinguished from one another.

A year-long project was initiated by the FBI and conducted by members of Oakridge National Laboratory (ORNL) to validate and optimize the performance of the STU-100. The research focused on three sample collection methods:

- 1) direct handling of cotton pads by individuals
- 2) sample collection from individuals' hands using an STU-100
- 3) sample collection from objects handled by individuals using an STU-100

Principal component analysis (PCA), a multivariate statistical method of reducing data, was used to determine if samples collected using methods 1) and 2) produced distinct results for each individual. PCA was also used to determine if samples collected using method 3) could be matched to those taken using methods 1) and 2). PCA requires original data to be grouped so that a smaller number of uncorrelated variables can be created to ease the comparison of a large amount of data. In this study, three variables were created using the data and plotted in a three-dimensional graph. The clustering of data points indicated minimal variation between the samples and was used as a means to match samples. PCA results could only distinguish between samples from different individuals that were collected by method 1). Samples collected by methods 2) and 3) could not be distinguished from one another. The experiments were repeated using heated cotton pads (85 °C for 24 hours) in an attempt to reduce the initial background signature of the pads. While the initial background signals were reduced, similar results were observed when the pads were heated. Another facet of this project involved the analysis of four colognes, which were considered to have a complex odor signature. The STU-100 was used to collect samples of the four colognes on pretreated (85 °C for 24 hours) cotton pads. Three of the four colognes were distinguishable from one another using PCA. [28]

Another set of experiments tested if the cotton pads would show differences between samples when different exposure techniques were used (i.e. headspace versus a liquid spike directly on the pad) and if different analytes could be distinguished from one

another using PCA. The following samples were analyzed: a) blank cotton pads, b) pads spiked with liquid heptanoic acid, c) pads exposed to the headspace over isovaleric acid, d) pads spiked with liquid isovaleric acid. All of the samples were distinguishable except the two isovaleric acid samples. The results indicate that different analytes on the cotton pads were distinguishable but samples of the same analyte administered to the pad by different means were indistinguishable. In addition, four colognes were analyzed to determine if complex mixtures could be distinguished. The results indicated that all four colognes were able to be distinguished from one another. [29]

The results of past experiments suggest that human scent collected on cotton pads by the STU-100 are at levels that do not allow current laboratory analysis techniques to distinguish between samples taken from different individuals. However, when less complex mixtures are sampled using the STU-100 distinction between samples is possible.

2.3.1.3. Alternative Sample Collection Media

A key to the performance of the STU-100 is the collection media. The more effective the collection media is at capturing and releasing human scent compounds the more likely the compounds will be collected at levels that can be measured and analyzed.

The performance of the cotton combine dressings and cotton surgical dressings were evaluated. The combine dressings were approximately 50% as effective in collecting and releasing picoline as the surgical dressings. The effectiveness of cleaning the combine dressings and surgical dressings via heating prior to use was also investigated. Results indicated that heating the cotton pads prior to use did not affect the performance of either type. [30]

Two alternative collection media, carbon based and reverse phase sulfonated disks, were evaluated to determine capture and release efficiency of isovaleric acid at room temperature. This experiment did not use the STU-100 for sample collection. An open bottle of isovaleric acid was placed in a chamber and allowed to equilibrate for several hours. The disks were placed in the chamber for two hours. When the disks were desorbed at room temperature and analyzed using a MS, no signal for isovaleric acid was observed. The results indicated that the two types of alternative collection media tested would likely not be effective for the room temperature collection and desorption of human scent compounds. [31]

While these studies provide preliminary data as to the effectiveness of the different collection media, the studies were limited in scope. To date only the four previously mentioned types of collection media have been tested with three analytes (picoline, heptanoic acid, and isovaleric acid) and a small number of humans have been sampled with the STU-100 for laboratory analysis.

2.3.1.4. Cotton Pad Absorption/Desorption Efficiency Evaluations

A critical measure of how effectively the STU-100 can be used to collect scent evidence is how efficiently the collection media can trap and release human scent compounds at room temperature. Several studies have been conducted which explore this aspect of STU-100 efficiency.

One study focused on determining the optimal face velocity (30, 40, or 75 ft/min) and extraction time (10, 30, or 60 seconds) when using an STU-100. The absorption/desorption efficiency of the cotton surgical dressing was evaluated using picoline. The pads were either heated (75°C for 18 hours) prior to use and stored in a

dessicator or taken directly from the package. The lowest face velocity setting, 30 ft/min, yielded the highest analyte signal. There was no significant difference in performance of the pads that were heated prior to use and those that were not. The authors concluded that extraction time was not a significant factor in analyte collection efficiency, but that a lower flow rate maximized analyte collection. [30]

Another study explored the ability of the cotton surgical dressings to trap and release multiple chemical compounds. The surgical dressings were spiked with 1 μL of a five-component mixture (1,1-dichloroethene, benzene, trichloroethylene, toluene, and chlorobenzene), sealed in a Tedlar™ bag, and allowed to equilibrate (for one and 72 hours) at room temperature. Headspace samples were collected and concentrated. GC/MS was used to analyze the samples. The mass of each analyte recovered was compared to the initial mass applied to the pad and a percent recovery for each analyte was calculated. In general, the percent recoveries of the pads placed in the Tedlar™ bags for 72 hours were less than those of the pads placed in the Tedlar™ bags for only one hour. Escape of the analytes from the bag or adsorption of the analytes to the surface of the bag may have contributed to the lower recoveries measured after 72 hours. However, all five analytes were detected after 72 hours in the bags.

An additional experiment using a 39 volatile organic compound mixture, Environmental Protection Agency (EPA) compendium Toxic Organic (TO-14A), was conducted with the STU-100 operating at its highest velocity setting (75 ft/min). The gas delivery outlet was placed 0.5 cm from the face of the STU-100. The gas mixture was delivered at 20 ppb_v at a flow rate of 0.5 L/min for 2 minutes. Each surgical dressing was then sealed in 3-liter Tedlar™ bag with 0.5 L of purified air and allowed to

equilibrate for 3 hours. Analysis showed that only 15 of the 39 analytes were detected after desorption. When the experiment was repeated with the STU-100's vacuum pump turned off, 30 of the 39 analytes were detected after desorption. Additional factors may have contributed to these findings, such as the inability of the cotton pads to efficiently collect volatiles and that the pads may require a higher temperature to release all of the analytes collected. [29]

To date, there have not been any studies performed to evaluate the collection media's performance when the STU-100's flow rate and extraction time are varied simultaneously with more than one human scent compound.

Chapter 3. Methodology

The goal of this research was to determine the optimal operating parameters for the STU-100 (flow rate and extraction time) by measuring the percent recovery of 10 human scent compounds from cotton surgical dressings. Four additional collection media (two different types of cotton pads, Dutch and Hungarian), a carbon-coated foam, and a prototype high surface area solid-phase microextraction (HSA-SPME) device were tested using the same optimal operating parameters.

3.1. Method Development

Four analytical methods (super critical fluid extraction, liquid extraction, SPME, and headspace concentration) were evaluated to determine the best technique for collection and retrieval of 10 human scent compounds from the surgical dressings with subsequent GC/MS analysis.

Supercritical fluid extraction (SFE) was considered because SFE could potentially exhaustively extract analytes from the pads without damaging the pads. SFE with GC/MS has been used successfully in many areas of research such as identifying flavor and fragrance compounds and identifying compounds present on human hair [32-35]. Supercritical fluid extraction takes advantage of the unique properties of a compound when it is at a temperature and pressure above its critical point. A supercritical fluid is neither a gas nor a liquid but has properties intermediate to both. The fluid maintains the solvating power of a liquid and the transport properties of a gas allowing for intimate contact between the solvent and a solid matrix. Supercritical fluid

extraction has many advantages such as the use of non-toxic solvents (i.e. carbon dioxide), minimal degradation to thermally labile compounds, and the solvating power of the supercritical fluid can be controlled by pressure and temperature. However, because the pads were initially large and other technical difficulties SFE was not used in this study.

Liquid extraction was also tested as a human scent compound extraction technique. Methanol was initially used as the extracting solvent, however experiments produced irregular peak areas and poor chromatography. Methylene chloride was ultimately used due to more acceptable chromatographic results. The surgical dressings were exposed to 17 human scent compounds and then rinsed with 20 mL of methylene chloride. A solvent volume of 20 mL was determined to be the minimum amount of solvent needed to ensure complete contact with the surgical dressing. A vacuum flask with a sintered glass filter was used to remove the methylene chloride from the surgical dressings. However, the use of a vacuum caused extensive evaporative losses of methylene chloride (over half the volume) and likely the analytes as well, therefore, use of the vacuum flask was discontinued. Instead, the exposed surgical dressing and 20 mL of methylene chloride were placed in a glass beaker, capped, and agitated for approximately 30 seconds. A 1 μ L sample of the solvent/analyte mixture was injected into the GC/MS for separation and analysis. This technique was not effective largely due to the low analyte recoveries from the surgical dressings. The use of 20 mL of solvent to extract the analytes from the surgical dressings diluted the analytes to a level that was below the GC/MS detection limits.

In the third human scent compound extraction technique tested, a 75 μm carboxen/polydimethyl siloxane (PDMS) SPME fiber (Supelco, St. Louis, MO) was used to collect headspace samples above the surgical dressings. The surgical dressings were exposed to TO-14A gas mixture and immediately heat sealed in a 1 L Tedlar™ bag and 500 mL of helium was added. The surgical dressing was allowed to equilibrate in the Tedlar™ bag for one hour. A SPME fiber was then inserted into the septum of the Tedlar™ bag and a 3-minute sample was collected. The SPME fiber was then immediately placed in a GC injection port and thermally desorbed. Again, due to low analyte recoveries of the surgical dressings, and the dilution with 500 mL of helium, none of the analytes were detected by the MS.

The fourth human scent compound extraction technique used a 7100 Air Preconentrator (Entech Instruments, Simi Valley, CA) followed by a low-thermal-mass (LTM) GC/MS. The sample collection and integration of the preconcentrator with the LTM GC/MS will be discussed Section 3.2.5.

3.2. Analytical Technique

Figure 3-1 illustrates the four steps involved in analyzing the STU-100 pads and when the HSA-SPME device was tested. Each of the four steps will be discussed in the following sections.

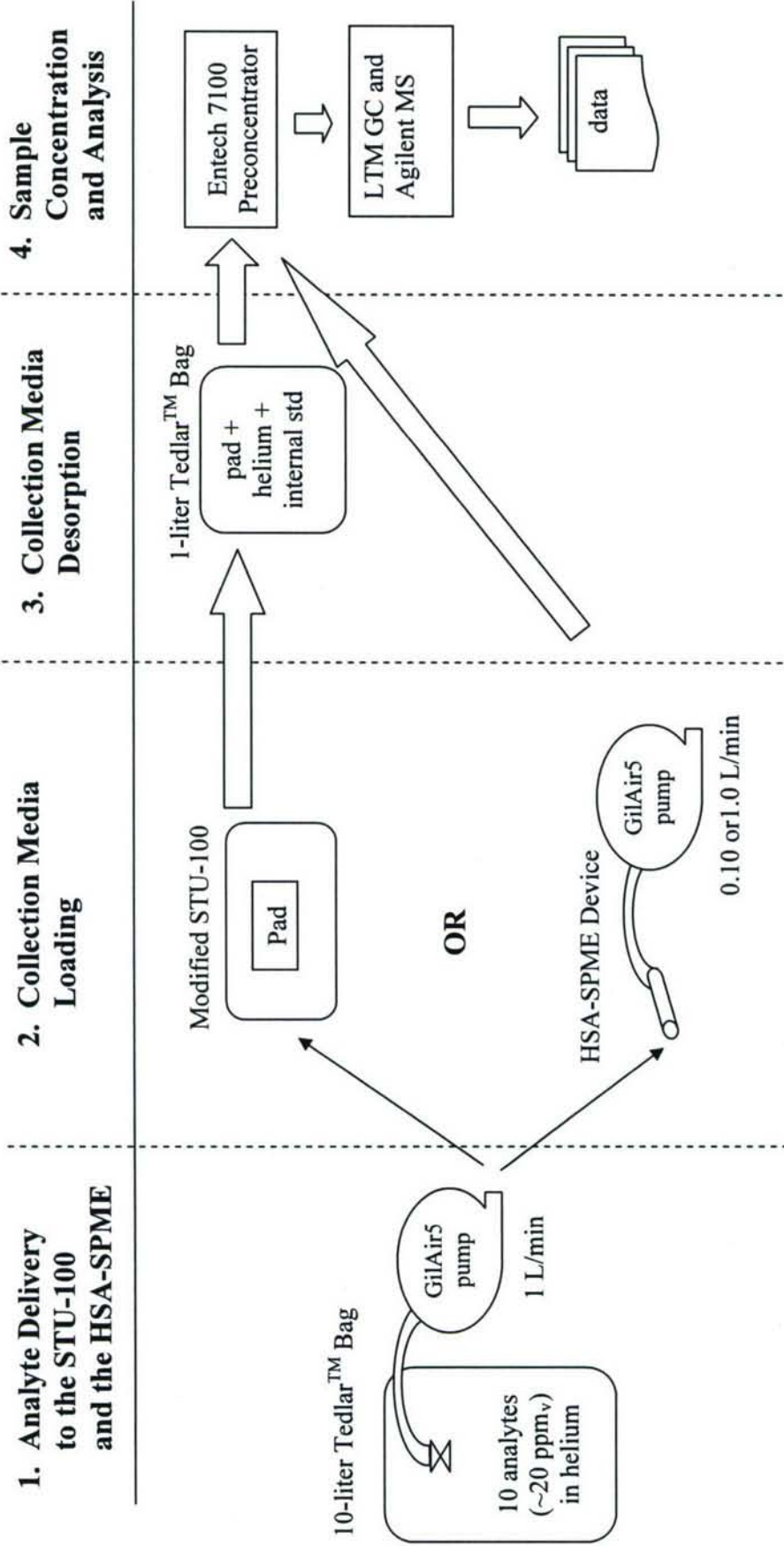

Figure 3-1. Schematic of Overall Experimental Process

3.2.1. Sample Preparation

While hundreds of compounds have been identified in human emanations, the selection of the 10 compounds used in this research (see Table 3-1) was based on the frequency of their appearance in past literature. These compounds are also representative of several compound classes.

Table 3-1. List of Human Scent Compounds Used

	Compound	Class
1	Benzyl Alcohol	alcohol
2	Phenol	alcohol
3	Decanal	aldehyde
4	Nonanal	aldehyde
5	Heptane	alkane
6	Hexanoic Acid	carboxylic acid
7	Octanoic Acid	carboxylic acid
8	Toluene	cyclic hydrocarbon
9	4-methyl-5-pentanone	ketone
10	6-methyl-5-hepte-2-one	ketone

All of the compounds listed in Table 3-1 are liquids at room temperature. A gaseous mixture of these compounds was required for delivery to the STU-100 pads. Samples were prepared by flushing Tedlar™ bags (10 L) three times with ultra high purity helium (Airgas, Radnor, PA). The bags were then filled to capacity with helium. A 10 μ L syringe (Hamilton Company, Reno, NV) was used to inject 1 μ L of each analyte into the Tedlar™ bag. The liquid injections were allowed to equilibrate for a minimum of 24 hours prior to use. Table 3-2 lists the gaseous concentration of each analyte generated in the Tedlar™ bags based on purity and density.

Table 3-2. Physical Properties of Selected Human Scent Compounds and Concentration in Tedlar™ Bags Used for Experimentation

Compound	Purity (%)	Molecular Weight (g/mol)	Density	Concentration (ppm _v)
Benzyl Alcohol	100	108.10	1.04	23.53
Phenol	90	94.10	1.06	24.68
Decanal	95	156.27	0.83	12.26
Nonanal	95	142.24	0.82	13.44
Heptane	100	100.21	0.68	16.69
Hexanoic Acid	100	116.16	0.93	19.41
Octanoic Acid	100	144.22	0.91	15.37
Toluene	99	92.14	0.87	22.78
4-methyl-2-pentanone	99	100.16	0.80	19.36
6-methyl-5-hepten-2-one	99	126.20	0.86	16.40

An internal standard was used to improve the precision and quantitative results. Benzyl chloride (126.59 g/mol) was selected because it is similar in structure and molecular weight to two of the analytes (toluene and phenol) used in this study. Benzyl chloride was obtained in a pressurized gas mixture (AirGas, Radnor, PA, benzyl chloride 1.06 ppm_w in nitrogen). By adding the same volume (100 mL) of internal standard to all the samples, each analytes' peak area could be compared to the area of the internal standard peak. An adjusted peak area was then calculated and used to determine the concentration of each analyte in the sample.

3.2.2. Analyte Delivery to the STU-100 and HSA SPME

A GilAir5 Tri Mode Air Sampler Pump (Sensidyne, Clearwater, FL) was used to deliver analytes to the face of the STU-100 from a 10-liter Tedlar™ bag. The inlet of the GilAir5 pump was attached to the bag with Tygon tubing (1.6 mm inner diameter, 4.8 mm outer diameter) (Saint-Gobain Performance Plastics Corp, Reading, PA). The outlet of the GilAir5 pump was fitted with Teflon tubing (1.5 mm inner diameter, 3 mm outer

diameter) (Supelco, Bellefonte, PA). The end of the Teflon tubing was held in place with a ring stand and a clamp and directed toward the face of the STU-100.

One of the main goals of using the STU-100 is to preserve forensic evidence at a crime scene. To ensure that this goal is achieved the STU-100's suction must not be so strong that it picks up other potential evidence (hairs, fibers, skin cells, etc.). The weight and structure of forensic evidence that may be present is highly variable and will accordingly have different capture velocities. Therefore, the experimental setup used in this research is based on the lightest piece of forensic evidence since it will have the lowest capture velocity and shortest capture distance. In ventilation systems, capture velocity is defined as the air velocity at a specified distance from the entry point of an air duct which can capture contaminated air. The American Conference of Governmental Industrial Hygienist's (ACGIH) Industrial Ventilation Manual [36] recommends a capture velocity for very light particulate matter generated from "spraying, welding, and plating operations" of 100-200 ft/min. The air velocity at the face of the modified STU-100 (see section 3.2.3. for discussion of modification) has been measured. The highest flow rate recorded at the center of the face (at the highest vacuum setting), when a pad was in place was 126 ft/min. This is slightly above the minimum 100 ft/min capture velocity for light particulate matter. Therefore, the calculated distance at which the STU-100 must be held from the item it is collecting scent from to avoid disturbing other potential forensic evidence on that item is 0.60 cm (see Appendix B for calculations).

The GilAir5 pump outlet was placed 7.6 cm away from the pad (a convenient distance to use in a field setting), which is well past the minimum distance to avoid disturbance of other materials present. The pump outlet tubing was pointed toward the

center of the collection media. A ring stand and clamp were used to hold the STU-100's power control in the "on" position during runs. Prior to sampling, the GilAir5 pump was calibrated to 1.0 L/min (DryCal, DC-Lite, Bios, Butler, NJ). A cardboard shroud was placed around the pump outlet and STU-100 face to minimize the affect of air currents on analyte delivery.

The experiments involving the HSA-SPME device were slightly different from those that used the STU-100. The HSA-SPME device replaced the STU-100 in the experimental setup. The inlet of the HSA-SPME device was placed at the same distance (7.6 cm) as the STU-100 was from the delivery pump outlet. A second GilAir5 pump was needed to pull air (1.0 L/min and 0.10 L/min) and the analytes through the HSA-SPME device. The HSA-SPME GilAir5 pump was pre- and post-calibrated between sample sets.

3.2.3. Collection Media Loading

The surgical dressings used in the simplex optimization were Johnson and Johnson (Hospital Products for Home Care - Skillman, NJ) Surgipad Surgical Dressings (22.9 cm x 12.7 cm). Each surgical dressing was cut into nine equal pieces (7.6 cm x 4.2 cm). To avoid human scent contamination, gloves were worn while handling the surgical dressings. In addition, prior to cutting the surgical dressings the bench top, ruler, and scissors were cleaned with alcohol wipes. The STU-100 was also cleaned with alcohol wipes between each sample. All cut surgical dressings were stored in resealable plastic bags until use. Cutting the surgical dressings to a smaller size was done to determine if the size of the surgical dressing and therefore the size of the STU-100 could be reduced and still collect enough human scent compounds for GC/MS analysis. The

STU-100's faceplate was modified to accept the smaller pads (see Figure 3-2). A Teflon plate (15.2 cm x 8.5 cm x 3.2 mm) was fitted onto the face of the STU-100 to create a 5.1 cm by 3.1 cm opening for the smaller surgical dressings.

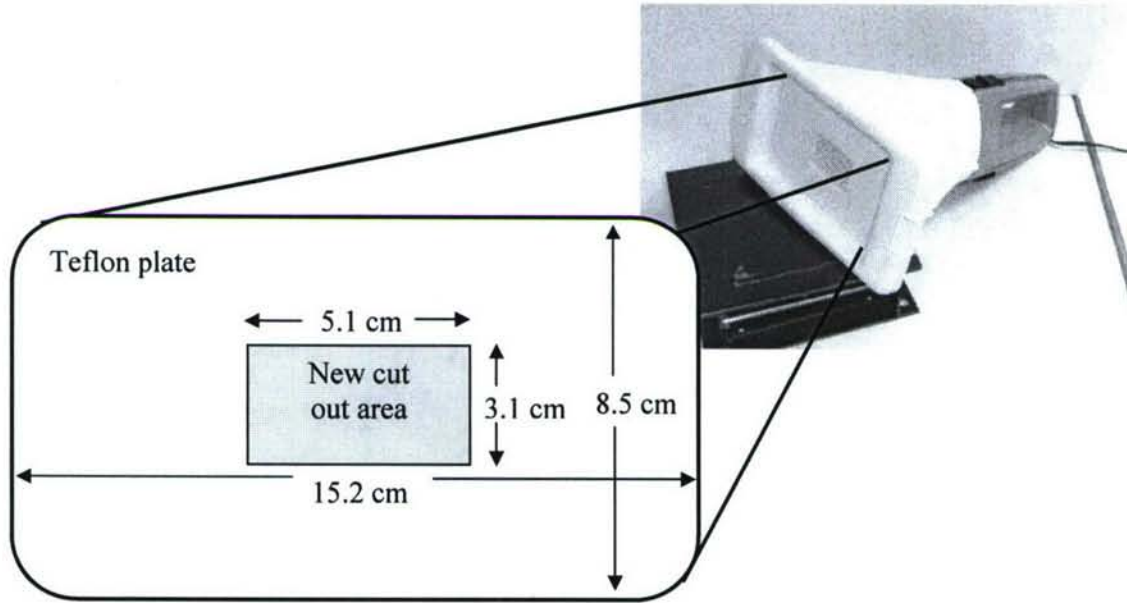

Figure 3-2. Schematic of Modified STU-100 Face Plate

The alternative collection media, Dutch and Hungarian cotton pads and carbon-coated foam pads, were cut to the same size as the surgical dressings and handled and stored as previously discussed. Two alternative types of cotton were structurally different from the surgical dressing. Both alternative types of cotton were woven differently and were thinner than the surgical dressing (see Figure 3-3). The carbon-coated foam pad was heated (200°C for 10 minutes) prior to each use to remove any remaining contaminants.

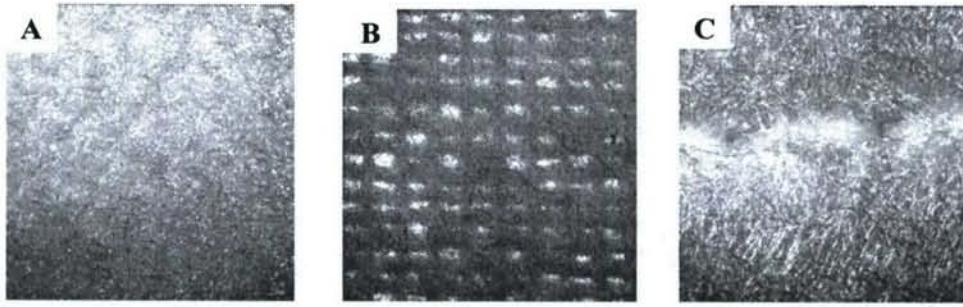

Figure 3-3. Three Types of Cotton Pads Tested: A) surgical dressing, B) Dutch cotton, C) Hungarian cotton (1.5x magnification)

A prototype HSA-SPME device was tested as an alternative collection media.

Figure 3-4 depicts a cross-sectional view of an HSA-SPME device. The HSA-SPME device [37] consists of a 10 cm long, 0.254 mm diameter nickel alloy wire coated with a 65 μm layer of carboxen/PDMS. The wire is coiled around a borosilicate glass tube (50 mm x 1.2 mm outer diameter 1.0 mm inner diameter) at a constant pitch with 2.2 mm between coils. This assembly is inserted into a larger (78.5 mm x 4.8 mm outer diameter x 3.0 mm inner diameter) borosilicate glass tube. Desorption of analytes from the HSA-SPME device was accomplished by resistively heating the wire using alternating current. The HSA-SPME device was conditioned prior to use (220°C for 30 minutes). During conditioning, helium was constantly being drawn through the HSA-SPME device at a rate of 200 mL/min.

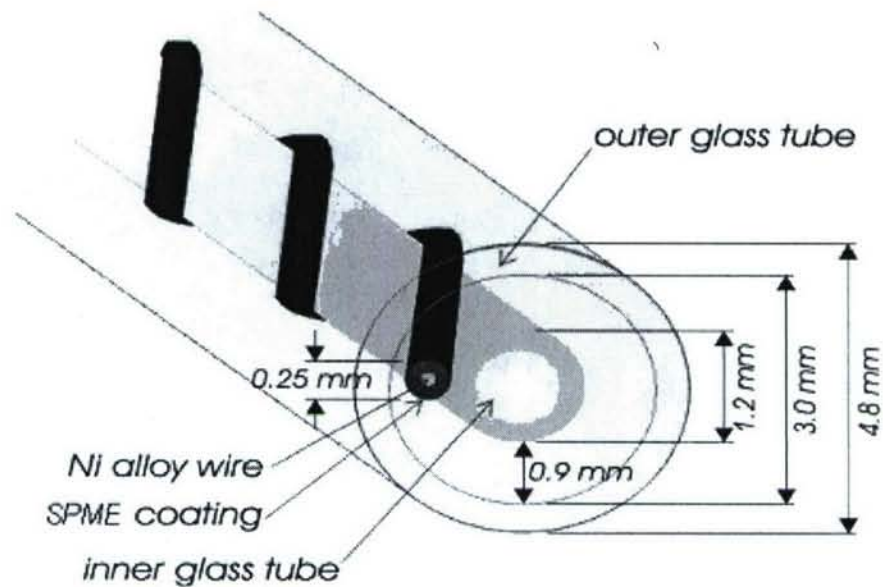

Figure 3-4. HSA-SPME Device Cross-Sectional View [38]

3.2.4. Collection Media Desorption

After each pad was exposed to the 10 human scent compounds, the pad was removed from the STU-100 and placed in a Tedlar™ bag (1 L) that had been cut to allow for insertion of the pad. The Tedlar™ bag was then sealed with an impulse heat sealer. A 491M gas generator (KinTek, Austin, TX) was used to deliver 500 mL of helium (Airgas, Radnor, PA) and 100 mL of the internal standard gas mixture (Airgas, Radnor, PA) to the Tedlar™ bag. The sample was allowed to equilibrate in the Tedlar™ bag for one hour before concentration and analysis. Since an equilibrium based desorption technique was used, the measured analyte recovery was not a total recovery. Analytes remained on the pads after desorption, however, this research assumes that analytes released in the headspace correlate with the total uptake and that by changing the STU-100 operating parameters different levels of uptake would be observed.

The HSA-SPME device sample desorption was conducted during a 3 minute period when the preconcentrator drew 600 mL of helium through the HSA-SPME device. Current was applied to the nickel alloy wire for 8 seconds to achieve a wire temperature of 250-300°C (manufacturer recommended). The current was monitored using a multimeter (3860 M, Metex Corporation, Seoul, Korea) and the wire temperature was monitored using a thermal imaging camera (Avio TVS 8500, Nippon Avionics, Tokyo, Japan).

3.2.5. Sample Concentration and Analysis

A three-stage Entech 7100 Preconcentrator (Simi Valley, CA) was used to concentrate the headspace from the pads prior to introduction into the GC/MS. The first stage contained cryogenically cooled glass beads, the second stage contained a cryogenically cooled sorbent bed (Tenax), and the third stage contained a cryogenically cooled focusing trap. The preconcentrator set points used in this research are listed in Table 3-3. The preconcentrator required a purge gas (nitrogen with a built-in-purifier, Airgas, Radnor, PA) and liquid nitrogen for cryogenic cooling (Airgas, Radnor, PA). Each day prior to running a blank, the system was set to bake for 40-60 minutes as a means to clean the system. In addition, a flushing program was initiated prior to each sample run.

Table 3-3. Entech 7100 Preconcentrator Operating Conditions

Component	Temperature (°C)
Inlet line:	120
Internal valve:	150
Transfer line:	150
Module 1 Trap	-150
Preheat	50
Desorb	70
Bake	200
Module 2 Trap	-50
Preheat	160
Desorb	180
Bake	190
Module 3 Trap	-160
Desorb	130
Transfer time (mins.)	2

A low thermal mass (LTM) A68 GC (RVM Scientific, Inc) was used instead of a convection heated GC column. LTM GC has demonstrated similar performance to a traditional lab-based GC and with several added advantages including lower power requirements, faster cooling times, and greater temperature ramping rates and range [39]. A DB-5ms LTM GC (3 m x 0.25 mm outer diameter x 0.25 μ m inner diameter) was fitted on the outside of the oven door of an Agilent 6890GC. For each sample, the LTM GC was initially held at 35°C for 2 minutes, ramped at 15°C/min to 200°C and held at 200°C for 2 minutes. The Agilent GC was used to control helium flow through the column as well as heat the transfer lines. The MSD was an Agilent 5973N. The GC/MS operating conditions are detailed in Table 3-4. The scanning range for the MSD was from 40 to 350 m/z. The GC/MS was controlled using ChemStation (version D.00.0038) software.

Table 3-4. GC/MS Operating Conditions

*Column operated in constant pressure mode.

Component	Temperature (°C)
Injector	200
Injector Transfer Line	200
Oven	200
MS Transfer Line	215
Column Head Pressure*	20 psi
MS Source	230
MS Quad	150

To verify the performance of GC/MS an autotune and an air and water check were performed each day prior to running any samples. In addition, a blank sample was run (500 mL helium and 100 mL of internal standard gas mixture) at the beginning of each day.

Calibration curves were used to relate a peak area from a total ion current chromatogram to an analyte concentration. Since low analyte recoveries were expected based on past research, the concentration range chosen for the calibration curves was low compared to the initial analyte concentration (20 ppm_v) to which the collection media was exposed. Concentrations of 20 ppb_v, 200 ppb_v, and 2 ppm_v were chosen for the calibration curve. The calibration curve samples were prepared by injecting various amounts of the 20 ppm_v mixture of the human scent compounds into Tedlar™ bags filled with helium (the calculations for the calibration curves are contained in Appendix A). The Tedlar™ bags containing the calibration curve samples were connected directly to the preconcentrator, no pads were used. Once a total ion current chromatogram was generated for a sample, ChemStation (version D.00.0038) and the NIST library were used to search for each of the analytes' and the internal standard's major ions. The peak area for the analytes and internal standard were then reported. Three samples were acquired at

each concentration and then averaged. An adjusted peak area was calculated for each analyte by dividing the analyte's peak area by the internal standard peak area. The combined peak area was calculated by summing the peak areas of five analytes. The combined peak area was also adjusted by dividing by the internal standard peak area. Two calibration curves were generated for each of the five analytes and the combined mixture of the five analytes. One curve related the adjusted analyte peak area to the concentration of the analyte (see Table A-2). These calibration curves were used to calculate the percent recoveries for the cotton pads. Due to very low internal standard recoveries for the carbon-coated foam and HSA-SPME device, a second set of calibration curves were constructed based on the analytes' unadjusted peak areas and did not use the internal standard peak area (see Table A-3). Weighted linear least squares regression was used to generate a trendline for each calibration curve. Since the variance for each data point was known, this model was chosen so that the non-homogeneity of the variance of each data point would be taken into account in the generation of the trendline. Because the data points are weighted by the reciprocal of their variances, there is more emphasis on data points with less variability. SPSS (release 12.0.1, 11 November 2003) was used to generate trendlines and R-squared values. Microsoft® Excel (2003 (11.8120.8122) SP2) was used to plot the trendlines.

The peak areas were used to calculate the concentration of each analyte using the calibration curve equations. The theoretical recovery was calculated by determining the mass of analyte that the pad was exposed to based on the initial analyte concentration in the Tedlar™ bag and the extraction time (delivery pump time on). The measured concentration was then divided by the theoretical concentration and multiplied by 100 to

yield the percent recovery of the analyte (sample calculations are contained in Appendix C). Each experiment at each flow rate and extraction time was repeated three times to ensure repeatable results. Relative standard deviations (RSDs) were calculated at each operating condition to evaluate the repeatability of the results.

The simplex method of optimization was used to determine the optimum flow rate and extraction time to maximize the recovery of the analytes from the surgical dressings. A simplex is a geometric figure that has as many vertexes as the number of factors to be optimized plus one. Therefore, in an optimization of two factors, the simplex has three vertexes and forms a triangle. Each vertex of the simplex corresponds to a set of experimental conditions.

The variable-size simplex method was chosen for this research. In all simplex optimization methods the researcher must choose the initial coordinates for the first simplex. Once the percent recovery of the human scent compounds was determined at each of the initial vertexes then a set of algorithms was used to calculate the next set of operating conditions to be evaluated (the next vertex). This process continued until the simplex converged on the conditions for optimal recovery. Figure 3-5 is a conceptual visualization of a simplex optimization. Additional detailed information on this optimization technique is provided in Appendix D.

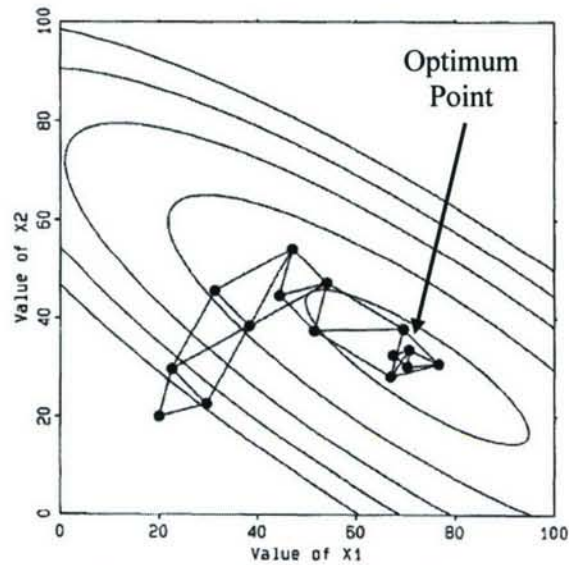

Figure 3-5. Example of a Completed Variable-Size Simplex Optimization [40]

3.2.6. Static SPME Experiment

An experiment was performed with a standard carboxen/PDMS SPME fiber (85 μm). The fiber was conditioned in a 300°C injection port of an Agilent GC/MS for 1 hour. The fiber was then inserted directly into a Tedlar™ bag containing a 20 ppm_v mixture of the 10 human scent compounds. The fiber was allowed to equilibrate in the Tedlar™ bag for 16 hours. The fiber was then inserted into an Agilent GC/MS for desorption and analysis. The GC inlet was 300°C and the oven was set to 35°C for 2 minutes followed by a 5°C /min ramp to 60°C and a 20°C /min ramp to the final temperature of 200°C.

Chapter 4. Results

4.1. Calibration Curves

Three samples were analyzed at three calibration curve concentrations (20 ppb_v, 200 ppb_v, and 2 ppm_v). Of the 10 human scent compounds present, only six were detected by the MS in the calibration curve samples (heptane, toluene, phenol, 6-methyl-5-hepten-2-one, nonanal, and decanal). Three-point calibration curves were only generated for five of the six compounds detected. Phenol's results were highly variable and phenol was detected in blank samples. Phenol was likely a contaminant from the Tedlar™ bags or a breakdown product from the Tenax trap in the preconcentrator, therefore phenol was not included in subsequent calculations or analysis. Table 4-1 shows the adjusted peak area (replicates have been averaged) for each analyte and its RSD. Excluding phenol, all but one of the RSDs were less than 20% at each concentration.

Table 4-1. Adjusted Peak Areas for Calibration Curves

Compound	20 ppb _v		200 ppb _v		2 ppm _v	
	Average Adjusted Peak Area	RSD (%)	Average Adjusted Peak Area	RSD (%)	Average Adjusted Peak Area	RSD (%)
Heptane	0.26	5	0.85	9	6.66	12
Toluene	1.47	5	4.32	8	20.94	15
Phenol	0.71	31	0.59	45	1.25	31
6-methyl-5-hepten-2-one	0.14	3	0.59	11	5.60	4
Nonanal	0.02	18	0.05	7	0.37	5
Decanal	0.03	16	0.15	13	1.27	23
Combined	1.92	4	5.96	9	34.82	12

Note: RSD > 20% are shaded

SPSS (release 12.0.1, 11 November 2003) was used to calculate trendline equations and R squared values based on a weighted linear least squares regression model. All the R squared values were greater than 0.94. See Appendix A for trendline equations.

4.2. Blanks

Two sets of blank samples were analyzed to better understand the background signal of the Tedlar™ bags and the surgical dressings and how heat sealing the Tedlar™ bags affected these signals. Helium (500 mL) and internal standard (100 mL) were added to empty heat sealed Tedlar™ bags and heat sealed Tedlar™ bags with a pad (no analytes sampled) in them. A flushing program on the preconcentrator was performed between each sample.

Table 4-2. Concentration of Analytes in Blank Samples

Compound	Empty Heat Sealed Bag		Heat Sealed Bag With Surgical Dressing	
	Average Concentration (ppb _v)	RSD (%)	Average Concentration (ppb _v)	RSD (%)
Heptane	0	0	0	0
Toluene	0	0	0	0
Phenol	2880	63	225	173
6-methyl-5-hepten-2-one	0	0	0	0
Nonanal	270	20	306	34
Decanal	0	0	0	0

Table 4-2 shows the measured concentration for each analyte from each set of blank runs (with and without a pad). The results indicate a significant amount of phenol and nonanal present in the blank samples with and without a pad.

4.3. Simplex Optimization

In the simplex optimization the flow rate and extraction time were varied simultaneously. The flow rate across the face of the STU-100 with the smaller surgical dressings in place was evaluated with a hot wire anemometer (Alnor, Skokie, IL). The STU-100's vacuum pump controller had markings from 1.0 to 9.4 with 0.20 demarcations. Readings were taken at every demarcation on the vacuum pump controller. The hot wire anemometer was placed approximately 0.60 cm from the surface of the pad. Five measurements were taken at each setting and averaged (see Figure 4-1). The RSDs for this data were all less than 10%. The average flow rates ranged from 52 ft/min to 126 ft/min. The trendline generated by Excel yielded an R squared value of 0.93. The flow rates assumed in this study are based on the trendline equation.

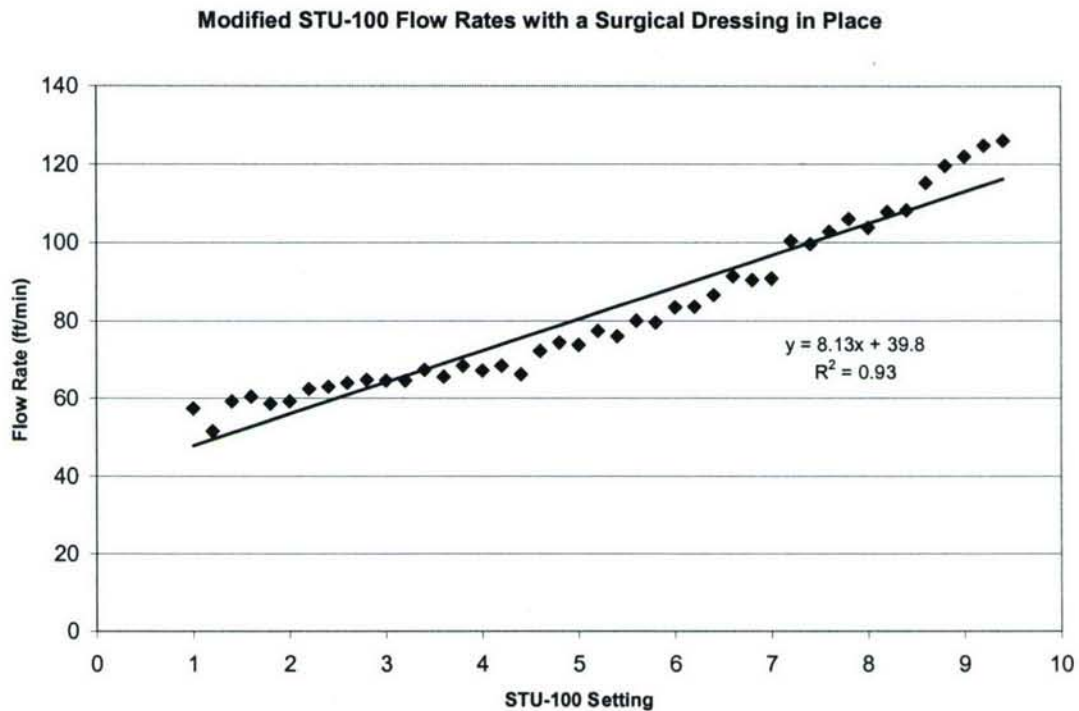

Figure 4-1. Modified STU-100 Flow Rate with a Surgical Dressing in Place

The coordinates for the initial simplex were located near the boundaries of the two parameters. The tested range of extraction times was 0.5 to 5 minutes and the flow rates ranged from 48 ft/min to 116 ft/min. Figure 4-2 shows the initial simplex used in the optimization.

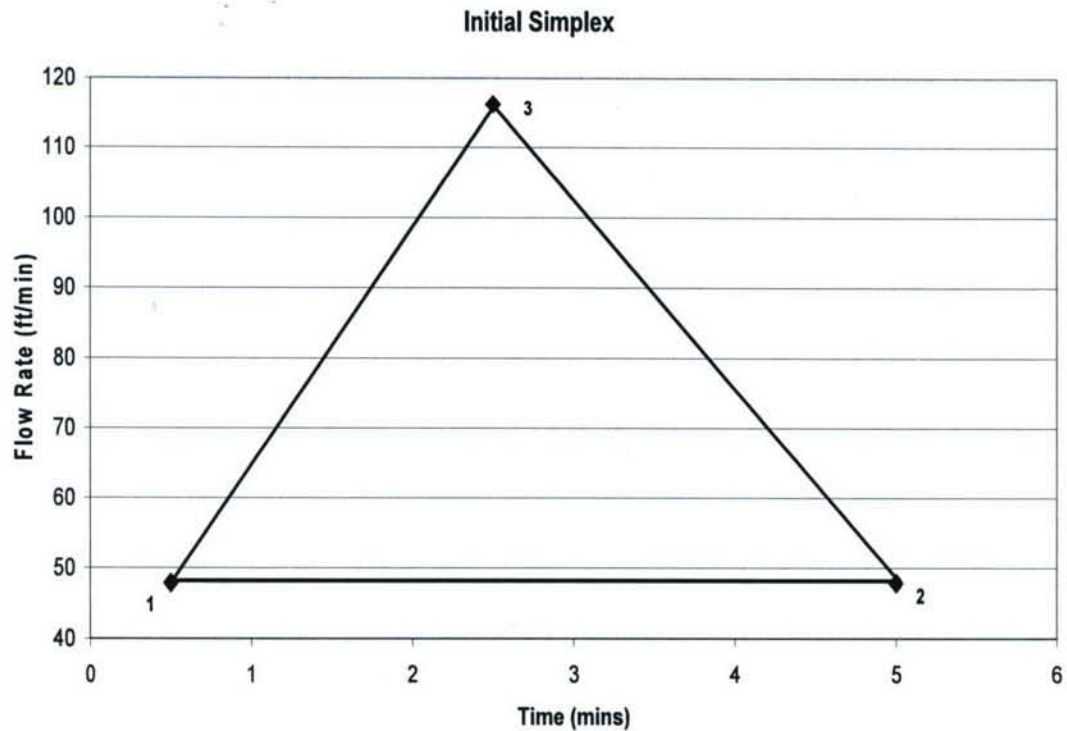

Figure 4-2. First Simplex Based on Researcher Chosen Data Points

Figure 4-3 shows all of the data points that were evaluated in the simplex optimization. Fourteen sets of operating conditions were evaluated to optimize the two parameters. The simplexes converged toward the lowest flow rate and lowest extraction time. Once the simplex calculations produced results that were similar to previously evaluated vertexes the optimization was considered complete. Vertex 21 (flow rate 50

ft/min, extraction time 0.90 mins) had the highest combined percent recovery of the five analytes and was considered the optimum operating condition.

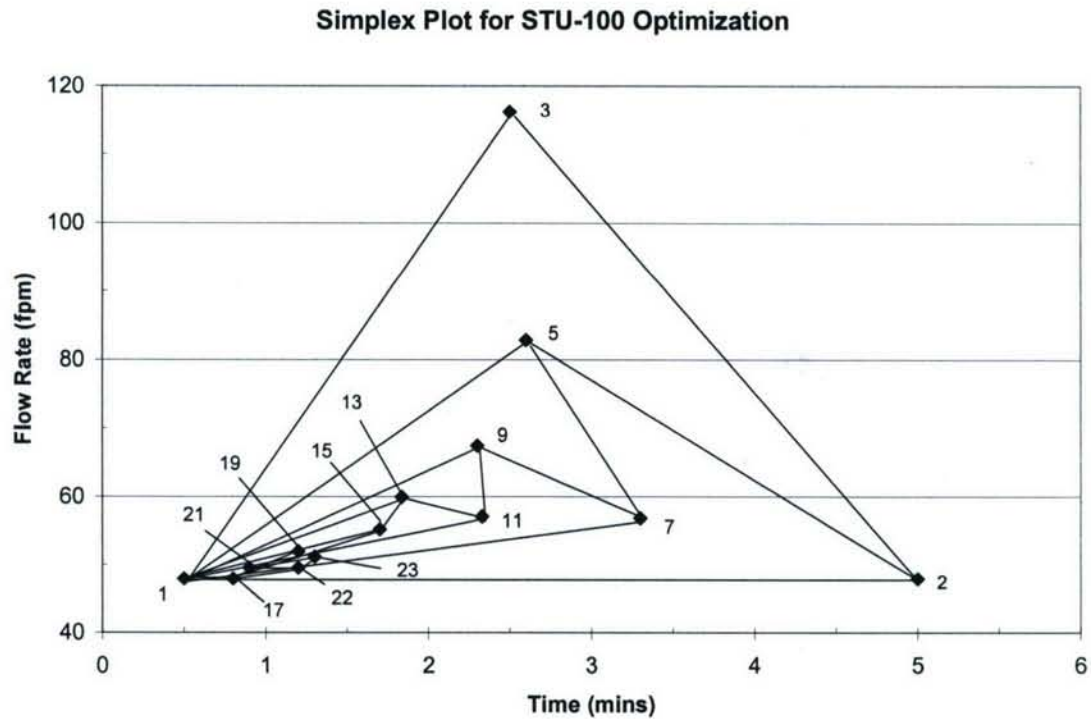

Figure 4-3. Plot of STU-100 Simplex Optimization

At the optimal conditions the combined analyte recovery (headspace of the analyte-loaded pad) was 1.8%. When the simplex calculations resulted in operating conditions that were outside the testable range, a response of zero percent recovery was assigned so that the optimization could continue. This adjustment is routinely employed in simplex optimizations. Not all the responses were significantly different from each other, but if the value of the response was greater than another response then the higher response was retained. Figure 4-4 shows the combined percent recovery at each of the simplex vertices evaluated. Vertex 21 produced the highest combined percent recovery (1.8%), but it was not significantly different from vertex 22 (1.4%).

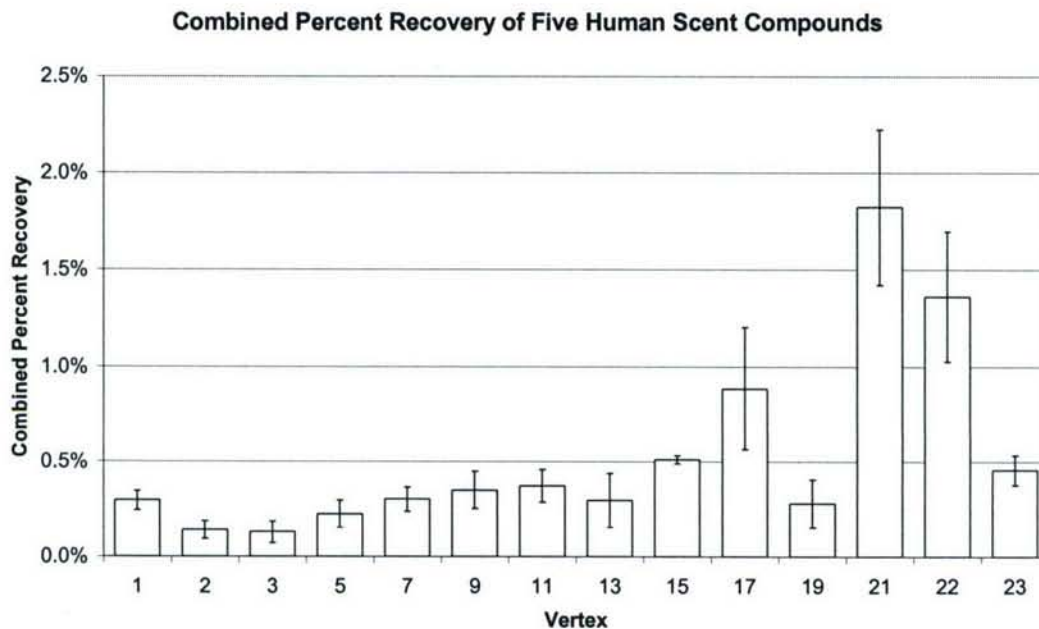

Figure 4-4. Combined Percent Recovery From Surgical Dressing (error bars represent \pm one standard deviation)

Figure 4-5 shows that the highest combined percent recovery of the five human scent compounds was achieved when the flow rate was low and the extraction time was short. However, none of the combined percent recoveries were greater than 2% which suggests that the surgical dressings are not efficient for standard analytical instrumentation at collecting and releasing the five human scent compounds at room temperature.

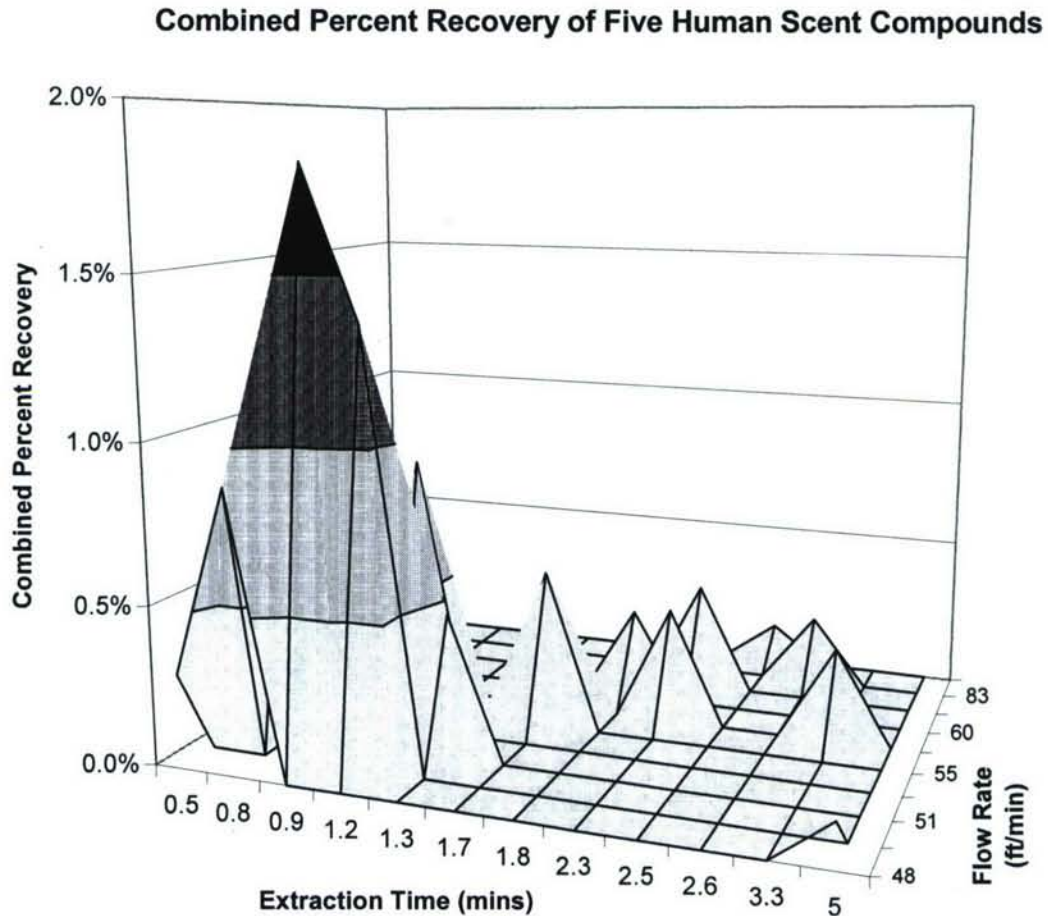

Figure 4-5. Combined Percent Recovery from Surgical Dressing

4.4. Comparison of Distance From Analyte Source

As previously discussed, to avoid the capture of forensic evidence other than scent, the STU-100 must be held at least 0.60 cm from the surface of the item from which scent is being collected. To investigate the affect of distance of the delivery pump outlet to the face of the STU-100, three distances (0.6 cm, 7.6 cm, and 15.2 cm) were tested. The simplex optimization was conducted with the delivery pump outlet 7.6 cm from the face of the STU-100. The other distances were tested at the optimal flow rate (50 ft/min) and

extraction time (0.90 mins). Figure 4-6 shows the results of these experiments. When the delivery pump outlet was placed 7.6 cm from the face of the STU-100, the highest combined percent recovery was achieved (1.8%). At the other two distances, the combined percent recoveries were significantly less than 1.8%, but not significantly different from one another.

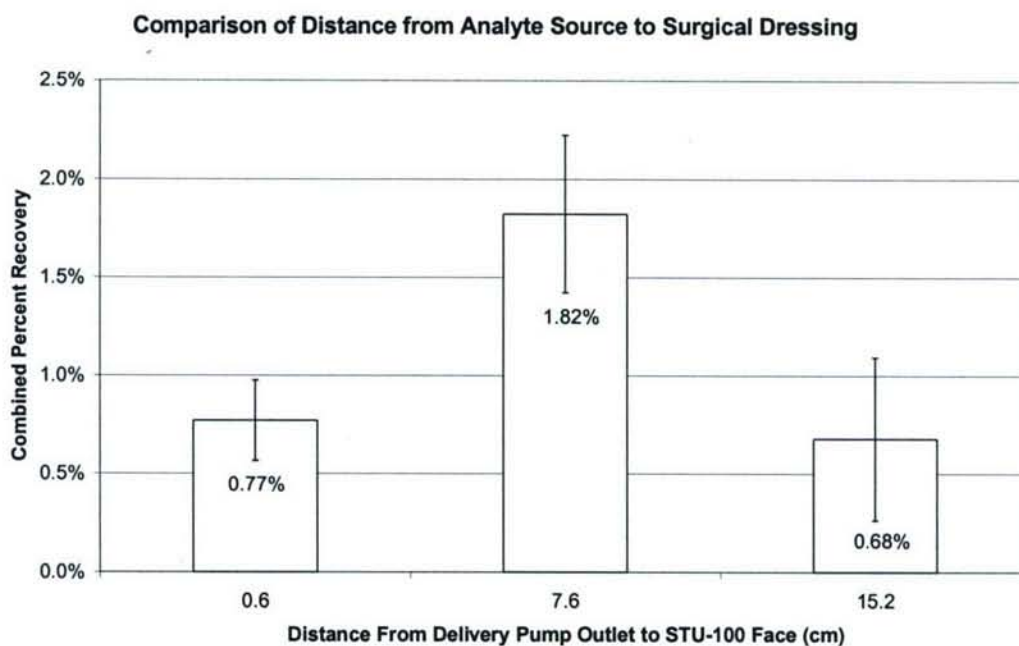

Figure 4-6. Combined Percent Recovery of Varying Distances of Delivery Pump Outlet to STU-100 Face (error bars represent \pm one standard deviation)

Figure 4-7 is a simplified diagram showing the different distances of the analyte pump outlet to the surgical dressing and how the distance affected analyte dispersion. At the shortest distance it is likely a lower analyte recovery resulted due to minimal dispersion of the analytes prior to making contact with the surgical dressing and quick saturation of the active sites in the small area of contact. At the longest distance, a greater percentage of the area of the surgical dressing came into contact with the analytes due to greater analyte dispersion. However, due to the lower concentration of analytes

reaching the surgical dressing it is likely that fewer active sites interacted (adsorption/absorption) with the analytes, resulting in a lower recovery.

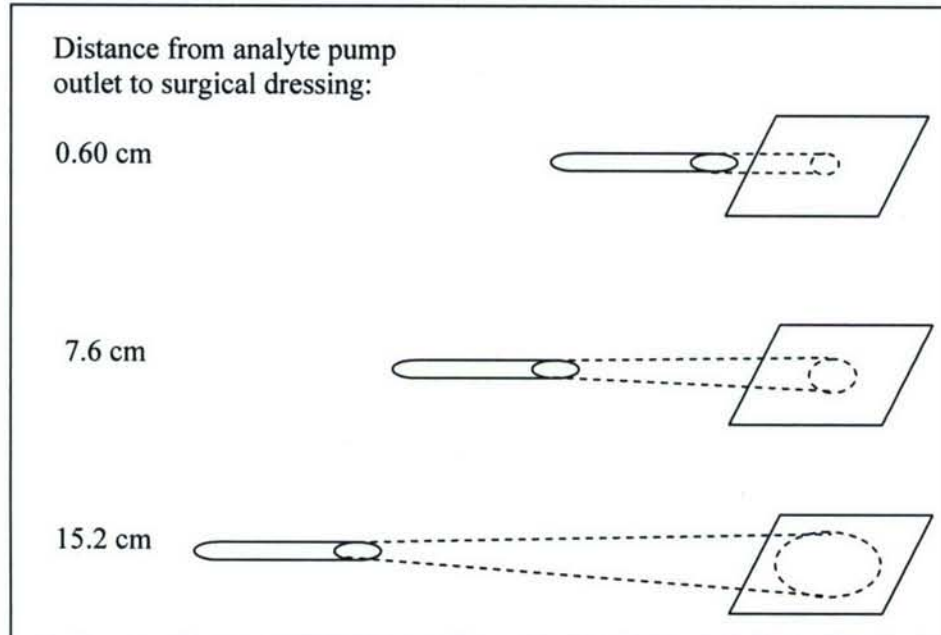

Figure 4-7. Diagram of Analyte Dispersal at Different Distances from Surgical Dressing (not to scale)

4.5. Surgical Dressing Size Comparison

Surgical dressings that were 1/9th the size of those normally used in the STU-100 were used in this research. A comparison of the performance of the smaller surgical dressing to that of a full sized surgical dressing was conducted at the optimal flow rate and extraction time, with the analyte source 7.6 cm from the pad. The results of this experiment are presented in Figure 4-8. The full sized surgical dressing collected and released approximately 3.7 times more of the human scent compounds than the smaller pad. However, because the full sized surgical dressing's recovery was not 9 times greater than the smaller surgical dressings's recovery, the difference in pad size cannot entirely account for the difference in the recoveries.

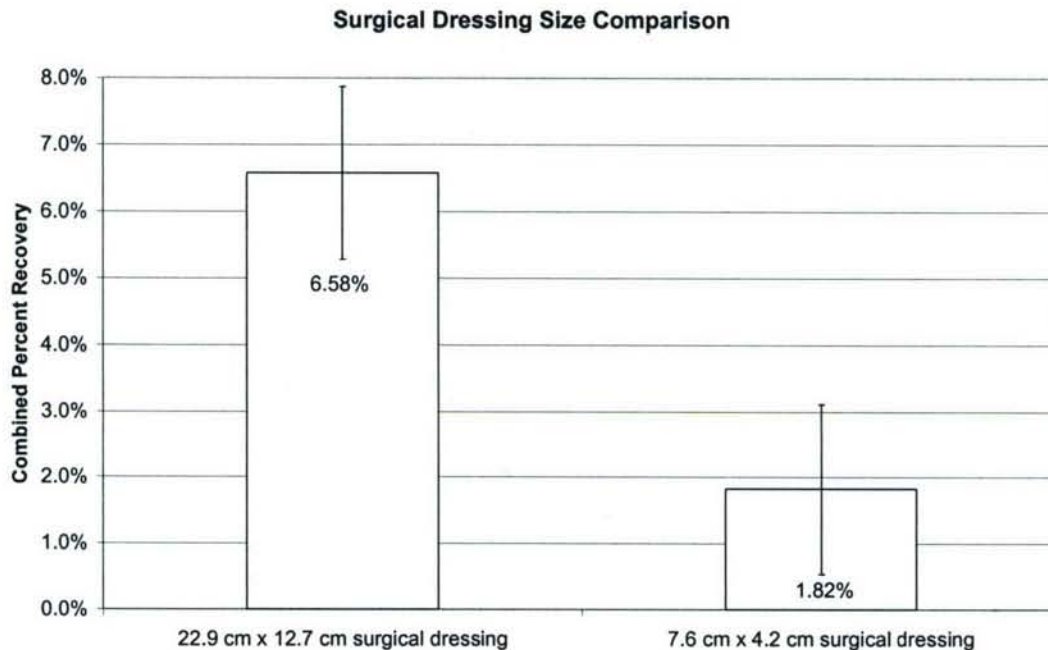

Figure 4-8. Combined Percent Recovery of Different Cotton Pad Sizes
(error bars represent \pm one standard deviation)

The observed differences in the analyte recoveries may be explained by the percentage of area of the surgical dressing that analytes contacted. Figure 4-9 depicts this concept visually. Since the analyte outlet was small compared to the full sized surgical dressing, many of the full sized surgical dressing's adsorptive sites may have never been exposed to the analytes and the adsorptive sites that were in the direct path of the analyte stream may have been quickly saturated. The percentage of area that was exposed to the analytes was much greater for the smaller surgical dressing. This may explain why the percent recovery of the analytes was not nine times greater in the full sized surgical dressing as compared to the smaller surgical dressing.

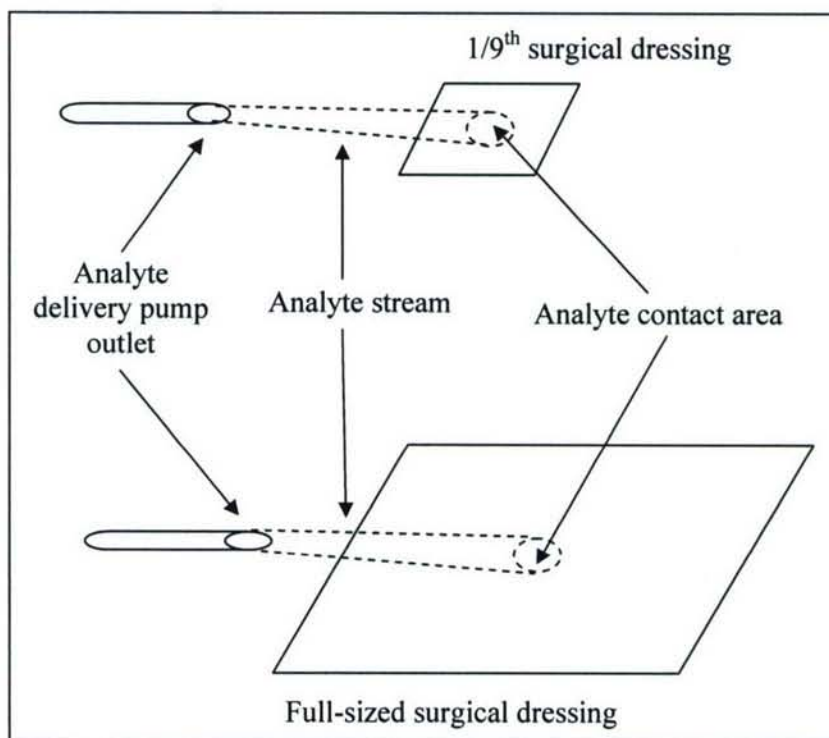

Figure 4-9. Diagram of Analyte Contact Area on Different Sized Surgical Dressings (not to scale)

4.6. Alternative Collection Media Comparison

Three alternative collection media were tested to compare their performance to the surgical dressing. Two alternative types of cotton were tested (Dutch and Hungarian) and the third pad material tested was a prototype carbon-coated foam. A HSA-SPME device was also tested, but was not a replacement for the collection media, but rather a replacement for the entire sample collection apparatus (the collection media and the STU-100). The HSA-SPME experiment was conducted twice, the first time with the HSA-SPME pump set to 1.0 L/min and the second time at 0.10 L/min. Figure 4-10 shows the combined percent recovery of the five analytes for each type of material tested. Due to the very low recovery of the internal standard for the carbon-coated foam and the HSA-

SPME device, the percent recoveries for these materials were not adjusted with the internal standard.

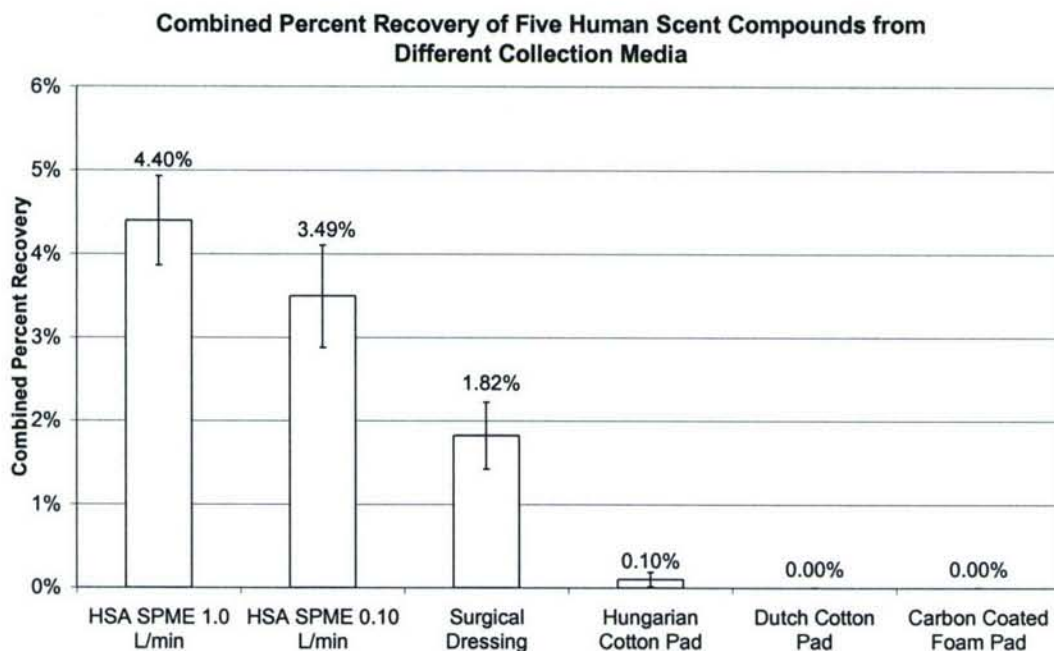

Figure 4-10. Comparison of Combined Percent Recoveries for Different Collection Media (error bars represent \pm one standard deviation)

Table 4-3 shows the percent recovery for each analyte for each type of collection media tested. The HSA-SPME device had the highest combined percent recovery for the five analytes, but only had measureable recoveries above the lower limit of the calibration curve for heptane and toluene. The results at the two different flow rates were similar, however the recoveries of the two compounds at the 1.0 L/min flow rate were slighter greater than those observed at the 0.10 L/min flow rate. However, the lower flow rate results in the detection of an additional analyte, nonanal. The two alternative cotton materials both had percent recoveries greater than the lower limit of the calibration range for nonanal. The Hungarian cotton also recovered a small amount of decanal. The

surgical dressing had recoveries of all five analytes that were greater than the lower limit of the calibration range. None of the analytes were recovered from the carbon-coated foam in amounts that were above the lower limit of the calibration curve.

Table 4-3. Percent Recovery of Human Scent Compounds for Five Collection Media

Collection Media	Heptane	Toluene	6-methyl-5-hepten-2-one	Nonanal	Decanal
HSA SPME (1.0 L/min)	6.77	3.65	0.00	0.00	0.00
HSA SPME (0.10 L/min)	5.30	2.94	0.00	0.35	0.00
Surgical Dressing	0.92	2.01	0.28	31.52	0.28
Hungarian Cotton	0.00	0.00	0.00	19.40	0.04
Dutch Cotton	0.00	0.00	0.00	1.36	0.00
Carbon-Coated Foam	0.00	0.00	0.00	0.00	0.00

Since the HSA-SPME experiments only resulted in recoveries of three of the nine (excluding phenol) human scent compounds, a headspace sample using a conventional SPME (Supelco, Belafonte, PA) fiber was performed to determine if the carboxen/PDMS polymer coating (85 μm) could effectively collect and release the 10 human scent compounds. GC/MS analysis revealed that the carboxen/PDMS polymer coating successfully collected and released nine of the 10 human scent compounds after a 16 hour exposure. 4-methyl-2-pentanone was not detected. The preconcentrator was not used in the conventional SPME experiment since the SPME fiber was desorbed directly into the GC injection port. Table 4-4 shows the human scent compounds collected by each method tested. If a compound was present at levels below the lower limit of the calibration curve, the compound was considered a non-detect. The SPME fiber collected

the greatest number of compounds compared to all the other methods. Quantitation of the conventional SPME results was not calculated because a calibration curve was not created for this collection method.

Table 4-4. Number of Human Scent Compounds Collected by Each Collection Media

Method	Number Human Scent Compounds Detected by GC/MS (of 9)*	Combined Percent Recovery
Surgical Dressing	5	1.82%
Hungarian Cotton	2	0.10%
Dutch Cotton	1	0.00%
Carbon-Coated Foam	0	0.00%
HSA SPME (0.10 L/min)	3	3.49%
HSA SPME (1.0 L/min)	2	4.40%
Conventional SPME	8	N/A**

*Compound was present at levels less than the lower limit of the calibration curve it was considered a non-detect.

**Quantitation was not performed since a calibration curve for this method was not created.

The preconcentrator was used in all experiments except the conventional SPME experiment. When the preconcentrator was used only five of the 10 human scent compounds were reliably detected, even during the development of the calibration curves. When the preconcentrator was not used, as with the conventional SPME experiment, eight (excluding phenol) of the 10 compounds were reliably detected with a GC/MS. This may indicate that analyte losses occurred in the preconcentrator.

Chapter 5. Conclusions

It has been scientifically proven that canines have the ability to match human scent samples, although results are variable and could be controversial in a court of law. If a canine's scent match can be verified by analytical methods, the value and reliability of a canine's scent match will be greatly improved. Several methods to collect human scent and deliver it to analytical instrumentation are tested in this research. The FBI and several other law enforcement agencies are using the STU-100 to collect scent evidence to ensure the preservation of other forensic evidence at crime scenes. Canines can detect human scent compounds at very low levels and the STU-100 collection technique has proven sufficient for canines. However, the collection of human scent compounds must be maximized for analytical instruments to be able to detect and identify the compounds in human scent samples.

5.1. Experimental Results

The results of these experiments indicate that the surgical dressing collection media was capable of collecting and releasing five (excluding phenol) of the 10 selected human scent compounds at room temperature. A low flow rate (50 ft/min) and short extraction time (0.90 mins) produced the highest analyte recoveries. Higher flow rates reduced the contact time between the human scent compounds and the collection media thus limiting the compounds adhesion to the collection media's adsorptive sites. It is also possible that active binding sites on the collection media were saturated resulting in loss of the human scent compounds via breakthrough.

The distance of the collection media from the analyte source also affected analyte recoveries. The results indicated that a distance of 7.6 cm provided the highest analyte recovery when compared to a much shorter distance (0.60 cm), and a much longer distance (15.2 cm). The analyte flow rate was the same at all distances, so at the closer distance less diffusion of the analytes likely caused a small area of the collection media to quickly reach equilibrium, while a large portion of the collection media was never in contact with the analytes. At the longer distance the analytes had time to diffuse and were likely much less concentrated when they reached the collection media. These theories could explain the lower analyte recoveries at the shorter and longer distances. Similarly, collection media size was a factor in analyte recovery. A larger surgical dressing (22.9 cm x 12.7 cm) allowed for greater analyte recovery when compared to a smaller surgical dressing (7.6 cm x 4.2 cm) although the recovery was not directly proportional to the size of the pad. This again was likely due to the small portion of the full pad that actually came into contact with the analytes.

When the STU-100 was used with various types of collection media, the recovery of 10 human scent compounds was low. Use of conventional SPME and a HSA-SPME device without the STU-100 resulted in higher recoveries. Only two flow rates (0.10 L/min and 1.0 L/min) were tested with the HSA-SPME device, so it is possible that other flow rates could improve collection efficiency. In addition, Carboxen/PDMS was the only polymer coating tested in both SPME experiments and other polymer coatings may prove to better collect and release human scent compounds. While use of the STU-100 with cotton surgical dressings has been shown to be sufficient for a canine's needs, the

recoveries are too low for analysis with currently available laboratory equipment. The data point toward the need for different collection media that is better able to trap and release human scent compounds at room temperature.

5.2. Study Limitations

The preconcentrator resulted in only six of the 10 human scent compounds being detected by the MS. A conventional SPME experiment was conducted without the preconcentrator and nine of the 10 human scent compounds were detected by the MS. This indicates that analyte losses may have occurred within the preconcentrator.

5.3. Future Research

There have been hundreds of compounds identified in human emanations, but only 10 were included in this research. Future research should include additional compounds. Also, investigation of more efficient extraction techniques which do not require concentration of the extract should be implemented. In addition, only four different types of collection media were used in this research and there are many other potential collection media that could be tested. Finally, additional exploration of the HSA-SPME collection device should include additional flow rates and polymer coatings.

Appendix A: Calibration Curve Calculations

Three-point calibration curves (20 ppb_v, 200 ppb_v, 2 ppm_v) were used in this research. The analyte concentration that the pads were exposed to was approximately 20 ppm_v (see Table 3-2 for exact analyte concentrations). Since past research indicated that recoveries less than 1% were likely, the lowest concentration used in the calibration curve was 20 ppb_v (which is equivalent to a 0.10% recovery). The highest concentration used in the calibration curve was 2 ppm_v (equivalent to a 10% recovery). The following calculations start by using the 20 ppm_v gas mixture, which was diluted to generate the three different concentrations needed for the calibration curve.

Equation A-1 was used to determine how the three required gas concentrations would be generated starting with the 20 ppm_v gas mixture.

$$C_1V_1 = C_2V_2 \quad \text{(Equation A-1)}$$

Where,

C_1 = the concentration of the original gas mixture (ppm or ppb)

C_2 = the desired gas mixture concentration (ppm or ppb)

V_1 = the amount of the original gas mixture required (mL)

V_2 = the total gas mixture volume (mL)

For the 20 ppb_v gas mixture:

$$\begin{aligned} V_1 &= \frac{C_2V_2}{C_1} \\ &= \frac{(20 \text{ ppb}_v)(3000 \text{ mL})}{20,000 \text{ ppb}_v} \\ &= 3 \text{ mL} \end{aligned}$$

Therefore, 3 mL of the 20 ppm_v gas mixture was added, using a 5 mL gas tight syringe, to 2997 mL of helium to generate 3 liters of a 20 ppb_v gas mixture. Similarly, calculations were done for the other two calibration curve concentrations.

Table A-1. Calibration Curve Mixture Volumes

Concentration	Volume of 20 ppm Mixture (mL)	Volume of He (mL)	Volume of Internal Std (mL)	Total Mixture Volume (mL)
20 ppb _v	3	2997	400	3400
200 ppb _v	30	2970	400	3400
2 ppm _v	300	2700	400	3400

Two calibration curves were generated for each of the five analytes and the mixture of the five analytes. One curve related the adjusted analyte peak area (analyte peak area divided by the internal standard peak area) to the concentration of the analyte (see Table A-2 and Figure A-1). These calibration curves were used to calculate the percent recoveries for the cotton pads. Due to very low internal standard recoveries for the carbon-coated foam and HSA-SPME device, a second set of calibration curves were constructed based on the analytes' unadjusted peak areas and did not use the internal standard peak area (see Table A-3 and Figure A-2). These calibration curves were related to mass, and not concentration as in the first set of calibration curves. Table A-2 lists the equations and R squared values generated by SPSS (release 12.0.1, 11 November 2003) for each of the analytes for both calibration curves sets.

Table A-2. Calibration Curve Equations Based on Adjusted Peak Area
 $y = \text{adjusted peak area} [(\text{analyte peak area})/(\text{internal standard peak area})]$, $x = \text{concentration (ppb}_v)$

Analyte	Equation of Linear Trendline	R Squared
Heptane	$y = 0.004x + 0.195$	1.000
Toluene	$y = 0.011x + 1.25$	0.945
6-methyl-5-hepten-2-one	$y = 0.003x + 0.085$	0.999
Nonanal	$y = 0.0003x + 0.016$	1.000
Decanal	$y = 0.001x + 0.017$	0.999
Total	$y = 0.019x + 1.561$	0.978

Heptane Adjusted Peak Area Calibration Curve

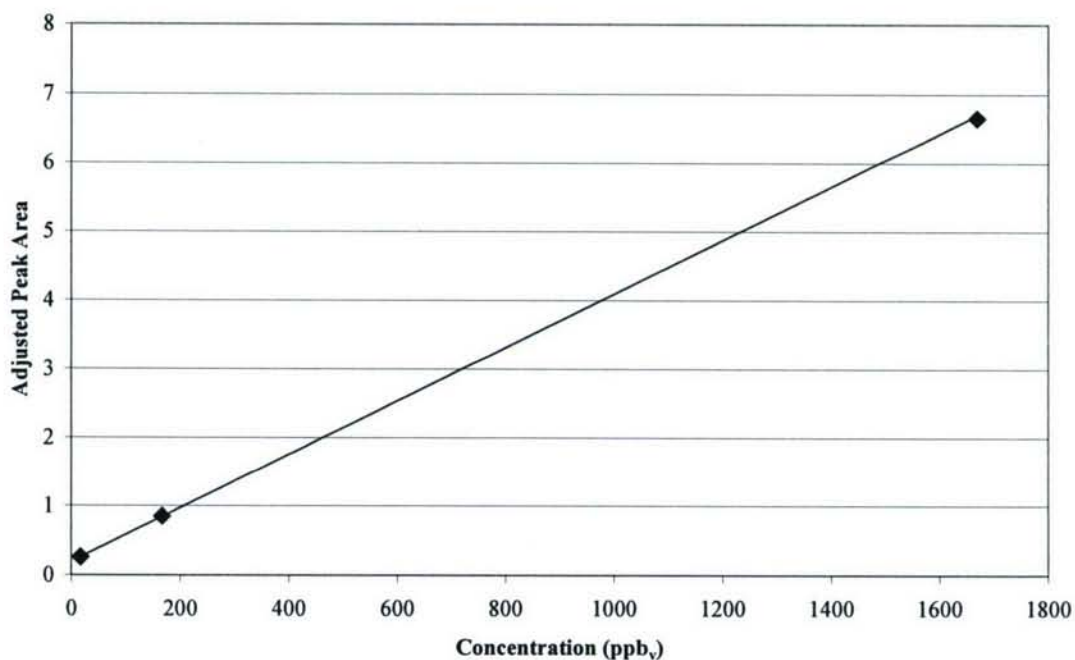

Figure A-1. Example of a Calibration Curve Generated Using Adjusted Peak Area

Table A-3. Calibration Curve Equations Based on Unadjusted Peak Areas
 y = analyte peak area, x = mass (ng)

Analyte	Equation of Linear Trendline	R Squared
Heptane	$y = 19692x + 4377860$	0.999
Toluene	$y = 64072x + 28350864$	0.982
6-methyl-5-hepten-2-one	$y = 13404x + 2038109$	1.000
Nonanal	$y = 804x + 319341$	0.989
Decanal	$y = 2631x + 463897$	0.998
Total	$y = 16773x + 35036616$	0.984

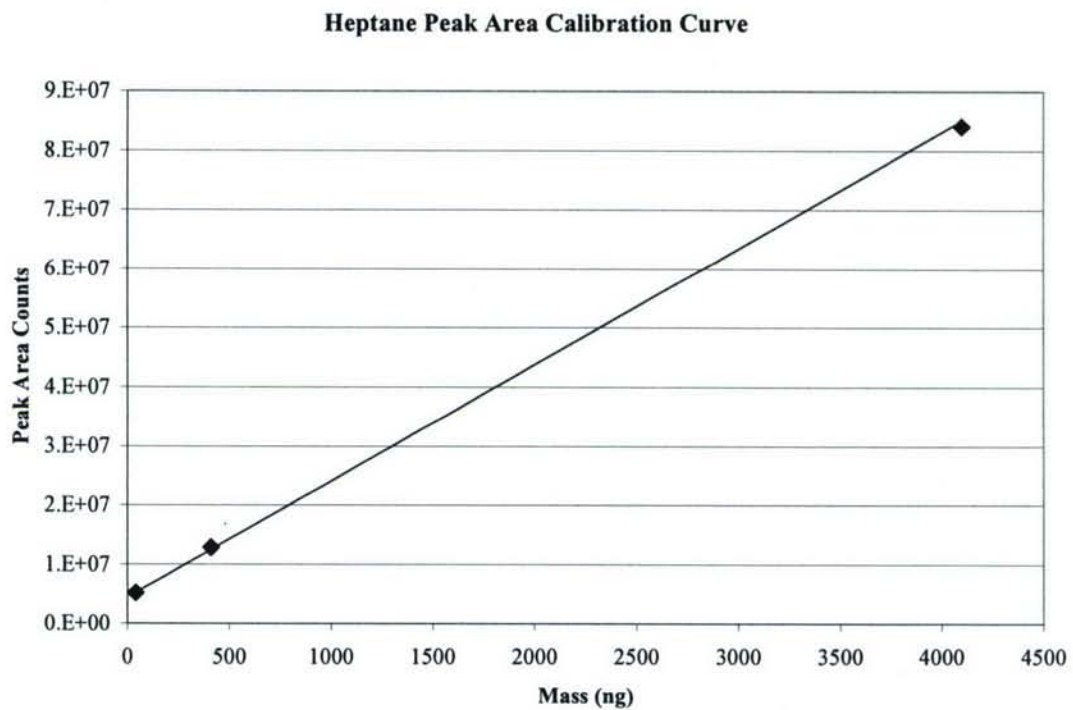

Figure A-2. Example of a Calibration Curve Generated Using Unadjusted Peak Area

Appendix B: Capture Distance Calculations

The equation from the ACGIH Industrial Ventilation Manual (25th edition) for the airflow of a rectangular flanged hood is:

$$Q = 0.75V(10X^2 + A) \quad \text{(Equation B-1)}$$

Where,

Q = airflow, cfm

V = velocity at distance X from the face of the hood, ft/min

X = distance from face of the hood, ft

A = area of the face of the hood, ft²

The area of the face of the modified STU-100 is:

A = length x width

= 5.1 cm x 3.1 cm

= 15.8 cm² = 0.017 ft²

To solve for Q at the face of the STU-100 (where X = 0) the following equation was used:

$$Q = V \times A \quad \text{(Equation B-2)}$$

Where,

Q = airflow, cfm

V = velocity at distance X from the face of the hood, ft/min

A = area of the face of the hood, ft²

= 126 ft/min x 0.017 ft²

= 1.6 cfm

Using 100 ft/min as the velocity (minimum capture velocity for particles) and solving for

X:

$$X = [(Q/0.75V) - A/10]^{1/2}$$

$$= [(1.6 \text{ cfm} / 0.75 * 100 \text{ ft/min}) - 0.017 \text{ ft}^2 / 10]^{1/2}$$

$$= 0.02 \text{ ft} = 0.60 \text{ cm}$$

Appendix C: Calculations of Percent Recovery for Released Targeted Compounds

The first step to determine the percent recovery of an analyte from a set of experiments was to determine the volume of the analyte mixture that was delivered to the pad. The delivery pump pre- and post-calibration flow rates were averaged and then multiplied by the extraction time to get the total volume of the analyte mixture delivered to the pad. Using the analyte concentration delivered to the pad (see Table 3-2) and the delivery volume, the mass of the analyte delivered to the pad was determined using Equation C-1.

$$\text{concentration ppm}_v = \left(\frac{\text{mass mg}}{\text{volume m}^3} \right) \left(\frac{24.45 \text{ m}^3/\text{mol}}{\text{mw g/mol}} \right) \quad \text{(Equation C-1)}$$

The theoretical concentration of the analyte was calculated by inputting the mass of the analyte delivered to the pad and the desorption volume (500 mL of helium + 100 mL of internal standard).

Now the actual measured concentration was calculated. The peak area for the internal standard and the analyte were obtained from ChemStation (version D.00.0038) and an adjusted peak area was calculated (analyte peak area/internal standard peak area). This adjusted peak area was used in the analyte's calibration curve equation (see Table A-2) to determine the actual analyte concentration.

Finally, the actual analyte concentration was divided by the theoretical concentration and multiplied by 100 to obtain a percent recovery of the analyte.

To illustrate this process the percent recovery for toluene is calculated below for the first run at vertex 1.

Delivery pump pre-calibration: 1.05 L/min

Delivery pump post-calibration: 1.04 L/min

Average: 1.05 L/min

Extraction time: 0.50 mins

Volume delivered to pad: $1.05 \text{ L/min} * 0.50 \text{ mins} = 0.52 \text{ L} = 0.00052 \text{ m}^3$

Theoretical concentration:

$$\text{mass mg} = \left(\frac{22.78 \text{ ppm}}{24.45 \text{ m}^3/\text{mol}} \right) (0.00052 \text{ m}^3) (92.14 \text{ g/mol})$$

$$\text{mass} = 0.0446 \text{ mg}$$

$$\text{concentration ppm}_v = \left(\frac{0.0446 \text{ mg}}{0.0006 \text{ m}^3} \right) \left(\frac{24.45 \text{ m}^3/\text{mol}}{92.14 \text{ g/mol}} \right)$$

$$= 19.72 \text{ ppm}_v$$

$$= 19,720 \text{ ppb}_v$$

Actual concentration:

Internal standard peak area: 3,307,769

Toluene peak area: 5,898,815

Adjusted toluene peak area: 1.78

Calibration curve equation (Table A-2): $y = 0.011x + 1.25$

$$y = 48 \text{ ppb}_v$$

Percent recovery:

Actual concentration/theoretical concentration * 100 %

$$= 48 \text{ ppb}_v / 19,720 \text{ ppb}_v * 100\%$$

= 0.24 % recovery of toluene

Appendix D: Simplex Method Detail

The simplex method of optimization is widely used in the scientific community. Simplex optimization has been used in the environmental, food, medical, pharmaceutical, and instrumentation arenas. Simplex optimization has been employed in the optimization of SPME procedures for antidepressant analysis [41], determining the best mix of ingredients for an infant food to provide the best nutritional value [42], optimization of phosphorus removal in water by varying the pH and the amount of coagulant used [43], optimization of large size DNA analysis [44], and in chromatographic separation optimizations [45-47]. Simplex optimization uses simple algorithms, evaluates interactive effects between factors, and narrows the optimal values of the factors, which limits the number of experiments required.

A simplex is a geometric figure that has as many vertexes as the number of factors to be optimized plus one. Therefore, in an optimization of two factors, the simplex has three vertexes and forms a triangle. Each vertex of the simplex corresponds to a set of experimental conditions. This research used a two-factor system (flow rate and extraction time). The researcher must choose the coordinates of the first simplex to begin the optimization. Once experiments are conducted at these points, the results of these experiments are ranked. The vertex providing the best result is labeled 'B,' the worst performer is labeled 'W,' and the next-to-the-worst performer is labeled 'N.' Once the vertexes are labeled, the vertex providing the worst result, W, is discarded. Next, the

centroid of the remaining hyperface, the line connecting vertexes B and N, must be calculated. The centroid is labeled 'P.' Figure D-1 shows this graphically, where the factors of interest are X1 and X2.

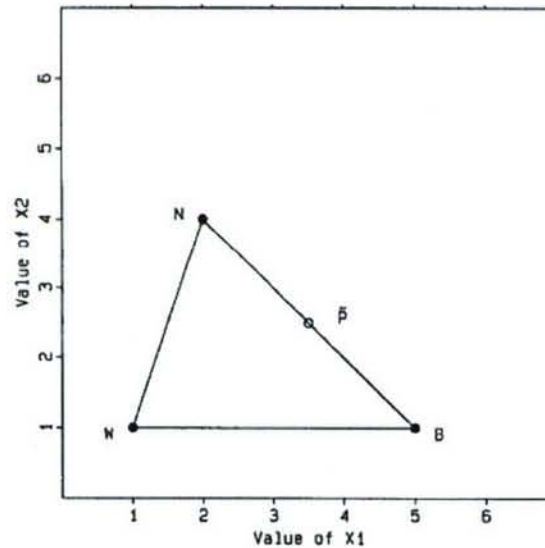

Figure D-1. A Two-Factor Simplex [40]

W = the worst response, N = the next-to-the-worst response, B = best response, P = centroid of the remaining hyperface

Now the reflection vertex, R, must be calculated. Figure D-2 shows the reflection vertex graphically. The vertex R is a reflection of the vertex that gave the worst response, W. This new vertex, R, corresponds to a new set of experimental conditions and must be evaluated. If the calculated R vertex corresponds to values of the factors that are outside of reasonable or possible values, then a percent recovery of zero was assigned to the vertex.

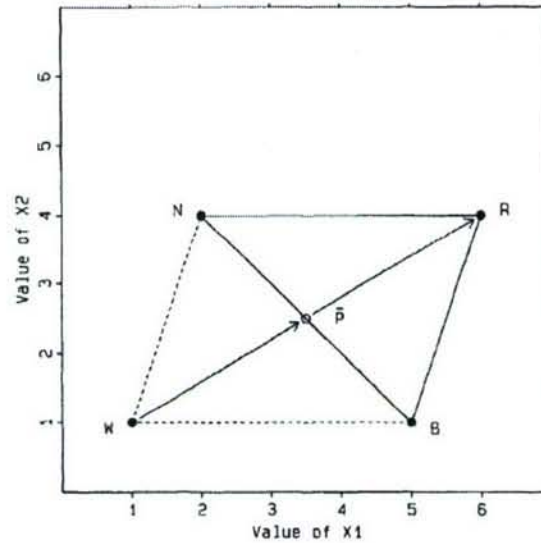

Figure D-2. Vertex R is the Reflection of the Discarded Vertex W [40].

Now the vertices of the new simplex that was generated as the result of the addition of R must be ranked as they were in the original simplex and the process repeated. In general, this is how simplex optimization is performed. The rules for the basic, or fixed-size, simplex methodology are:

1. Rank the vertices of the initial simplex (W, N, B).
2. Calculate and evaluate R.
3. Never transfer W to the next simplex. Always transfer the vertex labeled N to W in the next simplex. Rank the remaining vertices in the new simplex.

These simple steps are repeated until the optimum value is reached. Figure D-3 depicts a completed simplex optimization using the basic, fixed-size, technique.

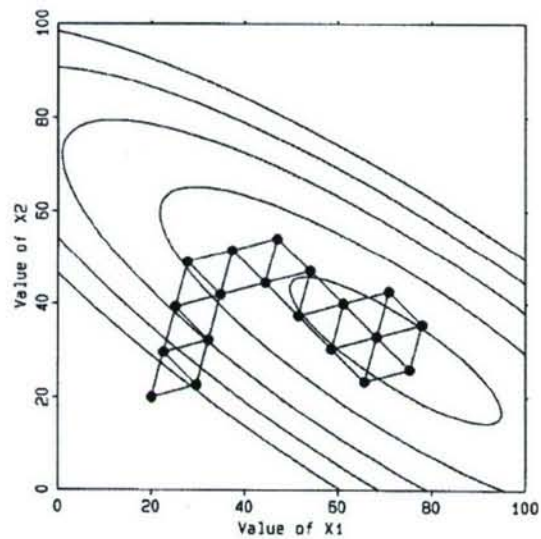

Figure D-3. An Example of a Completed Basic Simplex Optimization [40]

There is another simplex algorithm that allows the expansion and/or contraction of the simplex in favorable directions. Since this effectively changes the size of the simplex, this is often referred to as the variable-size simplex algorithm. It is this algorithm that is most often used in scientific research.

All of the possible vertexes in the variable-size simplex algorithm are shown in Figure D-4. The rules for the variable-size simplex algorithm are:

1. Rank the vertexes of the initial simplex (W, N, B).
2. Calculate and evaluate R .
 - a) If R is better than or equal to N and worse than or equal to B then use the BNR simplex.
 - b) If R is better than B then calculate and evaluate E :
 - i. If E is better than or equal to B then use simplex BNE
 - ii. If E is worse than B then use simplex BNR
 - c) If R is worse than N then:
 - i. If R is better than or equal to W then calculate and evaluate C_r and use simplex RNC_r
 - ii. If R is worse than W then calculate and evaluate C_w and use simplex RNC_w
3. Never transfer the vertex labeled W to the next simplex. Always transfer the vertex labeled N to the next simplex as W . Rank the other two vertexes.

Figure D-4 shows all the possible vertexes in the variable-size simplex optimization technique. Figure 3-5 shows a completed variable-size simplex optimization.

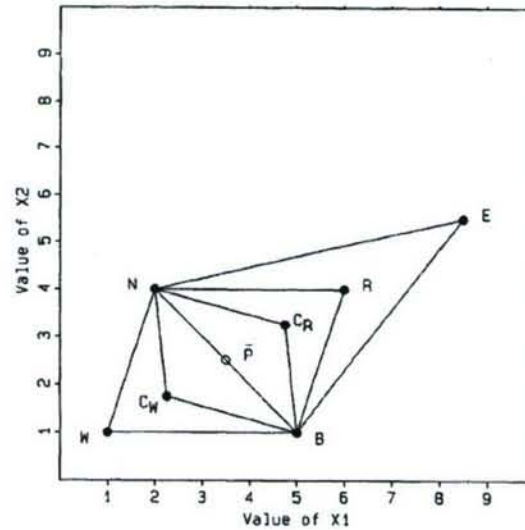

Figure D-4. All Possible Vertexes in the Variable-Size Simplex Algorithm [40]

A large initial simplex has been recommended for exploratory research since this allows for more coverage of the range of the factors being tested. Using the variable-size algorithm and a large initial simplex allows the simplex to collapse in on itself to reach the optimum more directly than starting with a smaller simplex. However, if there is some knowledge about the parameters being used and where the optimum is likely to lie, then a small starting simplex is recommended.

Bibliography

1. Tolhurst, B., *STU-100 Instructional DVD: Scent Evidence Collection for Law Enforcement*. 1996, Big Bill Tolhurst Enterprises, Inc.: USA. p. 12 mins. 40 secs.
2. Curran, A. M., S. I. Rabin, and K. G. Furton, *Analysis of the Uniqueness and Persistence of Human Scent*. Forensic Science Communications, 2005. 7(2).
3. Curran, A. M., S. I. Rabin, P. A. Prada, and K. G. Furton, *Comparison of the Volatile Organic Compounds Present in Human Odor Using SPME-GC/MS*. J Chem Ecol, 2005. 31(7): p. 1607-19.
4. Kanda, F., E. Yagi, M. Fukuda, K. Nakajima, T. Ohta, and O. Nakata, *Elucidation of Chemical Compounds Responsible for Foot Malodour*. Br J Dermatol, 1990. 122(6): p. 771-6.
5. Zeng, X., J. J. Leyden, H. J. Lawley, K. Sawano, I. Nohara, and G. Preti, *Analysis of Characteristic Odors From Human Male Axillae*. Journal of Chemical Ecology, 1991. 17(7): p. 1469-1492.
6. Zeng, X., Leyden, J. J., Brand, J. G., Spielman, A. I., McGinley, K. J., Preti, G., *An Investigation of Human Apocrine Gland Secretion for Axillary Odor Precursors*. Journal of Chemical Ecology, 1992. 18(7): p. 1039-55.
7. Zeng, X., J. J. Leyden, A. I. Spielman, and G. Preti, *Analysis of Characteristic Human Female Axillary Odors: Qualitative Comparison to Males*. Journal of Chemical Ecology, 1996. 22(2): p. 237-257.
8. Munk, S., P. Munch, L. Stahnke, J. Adler-Nissen, and P. Schieberle, *Primary Odorants of Laundry Soiled with Sweat/Sebum: Influence of Lipase on the Odor Profile*. Journal of Surfactants and Detergents, 2000. 3(4): p. 505-515.
9. Haze, S., Y. Gozu, S. Nakamura, Y. Kohno, K. Sawano, H. Ohta, and K. Yamazaki, *2-Nonenal Newly Found in Human Body Odor Tends to Increase With Aging*. J Invest Dermatol, 2001. 116(4): p. 520-4.
10. Ostrovskaya, A., P. A. Landa, M. Sokolinsky, A. D. Rosalia, and D. Maes, *Study And Identification of Volatile Compounds From Human Skin*. Journal of Cosmetic Science, 2001. 53(2): p. 147-148.
11. Lorenzo, N., T. Wan, R. J. Harper, Y. L. Hsu, M. Chow, S. Rose, and K. G. Furton, *Laboratory and Field Experiments Used to Identify Canis lupus var. familiaris Active Odor Signature Chemicals From Drugs, Explosives, and Humans*. Anal Bioanal Chem, 2003. 376(8): p. 1212-24.

12. Bernier, U. R., M. M. Booth, and R. A. Yost, *Analysis of Human Skin Emanations by Gas Chromatography/Mass Spectrometry. 1. Thermal Desorption of Attractants for the Yellow Fever Mosquito (Aedes aegypti) from Handled Glass Beads*. Anal Chem, 1999. **71**(1): p. 1-7.
13. Bernier, U. R., D. L. Kline, D. R. Barnard, C. E. Schreck, and R. A. Yost, *Analysis of Human Skin Emanations by Gas Chromatography/Mass Spectrometry. 2. Identification of Volatile Compounds That Are Candidate Attractants for the Yellow Fever Mosquito (Aedes aegypti)*. Anal Chem, 2000. **72**(4): p. 747-56.
14. Bernier, U. R., D. L. Kline, C. E. Schreck, R. A. Yost, and D. R. Barnard, *Chemical Analysis of Human Skin Emanations: Comparison of Volatiles from Humans That Differ in Attraction of Aedes aegypti (Diptera: Culicidae)*. J Am Mosq Control Assoc, 2002. **18**(3): p. 186-95.
15. Sommerville, B. and D. Gee, *Research on Body Odours: New Prospects for Combating Crime?* I. C. P. R., 1987. **July-August**: p. 18-22.
16. Sommerville, B. A., McCormick, James P., Broom, Donald M., *Analysis of Human Sweat Volatiles: An Example of Pattern Recognition In the Analysis and Interpretation of Gas Chromatograms*. Pesticide Science, 1994. **41**: p. 365-368.
17. Vass, A. A., R. R. Smith, C. V. Thompson, M. N. Burnett, D. A. Wolf, J. A. Synsteliën, N. Dulgerian, and B. A. Eckenrode, *Decompositional Odor Analysis Database*. J Forensic Sci, 2004. **49**(4): p. 760-9.
18. Wojcikiewicz, J., *Dog Scent Evidence. Is it Scientific?* Forensic-Evidence.com, 1999.
19. Schoon, G. A. A., *Scent Identification Lineups by Dogs (Canis familiaris): Experimental Design and Forensic Application*. Applied Animal Behaviour Science, 1996. **49**: p. 257-267.
20. Schoon, G. A., *A First Assessment of the Reliability of an Improved Scent Identification Line-Up*. J Forensic Sci, 1998. **43**(1): p. 70-5.
21. Brisbin, L., Austad S., *Testing the Individual Odour Theory of Canine Olfaction*. Animal Behavior, 1990. **42**: p. 63-9.
22. Harvey, L. M. and J. W. Harvey, *Reliability of Bloodhounds in Criminal Investigations*. J Forensic Sci, 2003. **48**(4): p. 811-6.
23. Stockham, R. A., Slavin, Dennis L., Kift, William, *Survivability of Human Scent*. Forensic Science Communications, 2004. **6**(4).

24. Stockham, R. A., D. L. Slavin, and W. Kift, *Specialized Use of Human Scent in Criminal Investigations*. Forensic Science Communications, 2004. **6**(3).
25. Kanable, R., *Collecting Scent as Evidence*. Law Enforcement Technology, 2003. **June**: p. 131-134.
26. Reza, H. G., *Hound Helper May Not Be Up to Snuff*, in *Los Angeles Times*. 2006: Los Angeles.
27. Van Berkel, G., Asano, K., *Improving the Performance of the Scent Transfer Unit (STU) - Quarterly Report (April-June 2006)*. 2006.
28. Van Berkel, G., Asano, K., *Improving the Performance of the Scent Transfer Unit (STU) - Quarterly Report (September-December 2005)*. 2005.
29. Eckenrode, B. A., S. A. Ramsey, R. A. Stockham, G. J. Van Berkel, K. G. Asano, and D. A. Wolf, *Performance Evaluation of the Scent Transfer Unit (STU-100) for Organic Compound Collection and Release*. Journal of Forensic Science, 2006. **51**(4): p. 780-789.
30. Van Berkel, G., Asano, K., *Improving the Performance of the Scent Transfer Unit (STU) Quarterly Report (July-September 2006)*. 2006.
31. Van Berkel, G., Asano, K., *Improving the Performance of the Scent Transfer Unit (STU) - Quarterly Report (January-March 2006)*. 2006.
32. Benner, B. A., Jr., J. V. Goodpaster, J. A. DeGrasse, L. A. Tully, and B. C. Levin, *Characterization of Surface Organic Components of Human Hair by On-Line Supercritical Fluid Extraction-Gas Chromatography/Mass Spectrometry: A Feasibility Study and Comparison with Human Identification Using Mitochondrial DNA Sequences*. J Forensic Sci, 2003. **48**(3): p. 554-63.
33. Hawthorne, S. B., M. S. Krieger, and D. J. Miller, *Analysis of Flavor and Fragrance Compounds Using Supercritical Fluid Extraction Coupled With Gas Chromatography*. Anal Chem, 1988. **60**(5): p. 472-7.
34. Hawthorne, S. B., D. J. Miller, and M. S. Krieger, *Coupled SFE-GC: A Rapid and Simple Technique for Extracting, Identifying, and Quantitating Organic Analytes from Solids and Sorbent Resins*. Journal of Chromatographic Science, 1989. **27**(July): p. 347-354.
35. King, J. W., *Fundamentals and Applications of Supercritical Fluid Extraction in Chromatographic Science*. Journal of Chromatographic Science, 1989. **27**: p. 355-364.

36. *Industrial Ventilation: A Manual of Recommended Practice*. 25th ed. 2004, Cincinnati, OH: The American Conference of Governmental Industrial Hygienists, Inc.
37. Mustacich, A., *Final Report: Adaptive Sampling Program*. 2003, Dept. of Justice, Federal Bureau of Investigation.
38. Ramsey, S., *Method Development of an Adaptive Air Sampling Device For Use With Portable Gas Chromatography in Filed Forensic Analyses*, in *School of Criminal Justice*. 2004, Michigan State University: East Lansing. p. 117.
39. Sloan, K. M., R. V. Mustacich, and B. A. Eckenrode, *Development and Evaluation of a Low Thermal Mass Gas Chromatograph For Rapid Forensic GC-MS Analyses*. *Field Analytical Chemistry and Technology*, 2001. **5**: p. 288-301.
40. Walters, F. H., Parker, Lloyd R., Morgan, Stephen L., Deming, Stanley N., *Sequential Simplex Optimization*. Chemometrics Series, ed. S.D. Brown. 1991, Boca Raton, FL: CRC Press Inc. 325.
41. Cantu, M. D., D. R. Toso, C. A. Lacerda, F. M. Lancas, E. Carrilho, and M. E. Queiroz, *Optimization of Solid-Phase Microextraction Procedures for the Determination of Tricyclic Antidepressants and Anticonvulsants in Plasma Samples by Liquid Chromatography*. *Anal Bioanal Chem*, 2006. **386**(2): p. 256-63.
42. Alarcon-Valdez, C., J. Milan-Carrillo, O. G. Cardenas-Valenzuela, R. Mora-Escobedo, L. A. Bello-Perez, and C. Reyes-Moreno, *Infant Food From Quality Protein Maize and Chickpea: Optimization for Preparing and Nutritional Properties*. *Int J Food Sci Nutr*, 2005. **56**(4): p. 273-85.
43. Wang, Y., T. Han, Z. Xu, G. Bao, and T. Zhu, *Optimization of Phosphorus Removal from Secondary Effluent Using Simplex Method in Tianjin, China*. *J Hazard Mater*, 2005. **121**(1-3): p. 183-6.
44. Catai, J. R., A. P. Formenton-Catai, and E. Carrilho, *Simplex Maximization of the Correlation Coefficient for DNA Sizing Analysis by Capillary Electrophoresis*. *Electrophoresis*, 2005. **26**(9): p. 1680-6.
45. Cimpoi, C., A. Hosu, and S. Hodisan, *Analysis of Some Steroids by Thin-Layer Chromatography Using Optimum Mobile Phases*. *J Pharm Biomed Anal*, 2006. **41**(2): p. 633-7.
46. Srijaranai, S., R. Burakham, T. Khammeng, and R. L. Deming, *Use of the Simplex Method to Optimize the Mobile Phase for the Micellar Chromatographic Separation of Inorganic Anions*. *Anal Bioanal Chem*, 2002. **374**(1): p. 145-7.

47. Karnka, R., M. Rayanakorn, S. Watanesk, and Y. Vaneesorn, *Optimization of High-Performance Liquid Chromatographic Parameters for the Determination of Capsaicinoid Compounds Using the Simplex Method*. *Anal Sci*, 2002. **18**(6): p. 661-5.

Curriculum Vitae

Captain Kendra Fletcher received her undergraduate degree in Chemical Engineering from Michigan Technological University in May 2001. She received a direct commission into the United States Air Force and entered active duty on 19 September 2002. From 2002 to 2005 she was stationed at Mountain Home AFB, ID where she served as the Bioenvironmental Engineering Deputy Flight Commander and the Base Radiation Safety Officer. She entered the Master of Science in Public Health graduate program at the Uniformed Services University of the Health Sciences, Bethesda, MD in July 2005. Upon graduation in June 2007, she will be assigned to the United States Air Force School of Aerospace Medicine, Brooks City Base, San Antonio, TX.